

hyperMILL®

2020.1



What's New?



 **OPEN MIND**
THE CAM FORCE

© The helmet was programmed and produced by hyperMILL.

What's New in 2020.1?

General improvements in the new version increase usability and the performance of programming. Efficient processing of rest material in corners is ensured by the new 3D and 5-Axis Corner Rest Machining. With the *hyperMILL*® AUTOMATION Center users can realize small automation tasks themselves. A new strategy for the machining of turbine blades with conical barrel cutters increases efficiency significantly.

Contents

General

Toolpath Display	3
Highlight Split Job	3
Settings Wizard	3

CAM – Probing

Highlight Slot-Rib Probing	4
-----------------------------------	---

CAM – 3D Strategies

Highlight 3D Optimized Roughing	4
3D Plane Machining	4
Highlight 3D Profile Finishing	5
3D Equidistant Finishing	5
Highlight 3D and 5-Axis Corner Rest Machining	5

CAM – Additive Manufacturing

Highlight <i>hyperMILL</i> ® ADDITIVE Manufacturing	6
--	---

CAM – 5-Axis Strategies

5-Axis Contouring	8
-------------------	---

CAM – 5-Axis Special Applications

5-Axis Tube Finishing	8
Highlight 5-Axis Blade Tangent Machining	8

CAM – Grinding Strategies

Hole Grinding	9
2D Contour Grinding on 3D Model	9

Feature and Macro Technology

Macro – Compound Job	9
Feature – Close Pockets	9

CAM – Mill Turning

Parting	10
Highlight Automatic Contour Feature Splitting	10
Finishing	10
3-Axis Simultaneous Turning	10

CAM – Automation

Highlight <i>hyperMILL</i> ® AUTOMATION Center	11
---	----

CAM – VIRTUAL Machining

Highlight New Functions in 2020.1	12
--	----

CAD Integration: *hyperCAD*®-S

Move and Copy	14
Highlight Side Electrodes	14
Highlight Align Faces Orientation	14
Layer Containers	15
Layer Search	15
Associative Workplane	15

Review system compatibility: To ensure optimal performance and stability, we recommend regularly running our diagnostic program, Systemchecktool.exe.

Note: Windows® 10 may reset the graphics driver or its settings when carrying out updates. **System requirements:** Windows® 7 (64 Bit), Windows® 8.1 Pro and Windows® 10 | **CAD Integrations:** *hyperCAD*®-S, Autodesk® Inventor®, SOLIDWORKS, ThinkDesign, *hyperCAD*® | **Software languages:** de, en, es, fr, it, nl, cs, pl, ru, sl, pt-br, ja, ko, zh-cn, zh-tw

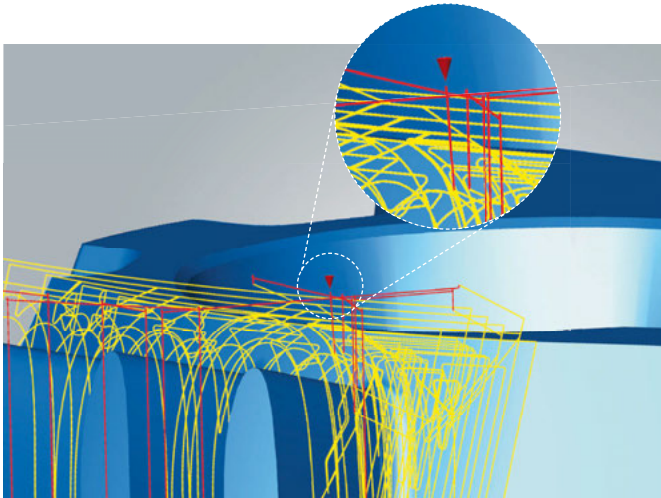

Toolpath Display

The start point of the toolpath is now marked with a small red arrow, making the start position and direction immediately recognizable.

Properties of toolpaths and points, as well as the tool axes, can now be edited in the jobs without recalculation. The compensated path can now also be graphically displayed in *hyperMILL*®.

Benefit: Improved overview.

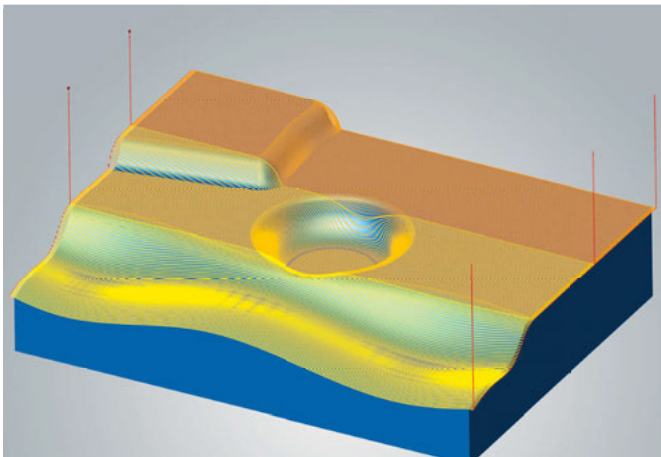

Highlight

Split Job

hyperMILL® now makes it possible to automatically split toolpaths according to a range of criteria. This makes it possible to easily change tools after a defined period of time or toolpath length, for example. Particularly in the case of materials that are difficult to machine, this provides optimal control over the tool life, making it possible to change inserts or switch in a sister tool, for example.

This function makes it unnecessary to manually edit the toolpath. Repeatability is guaranteed, even if the initial job is changed.

This function is available in all 3D and 5-axis cavity strategies.

Benefit: Increased process reliability.

Settings Wizard

The Settings Wizard makes it easy to export all *hyperMILL*® settings, postprocessors, machine models, and the tool and macro database, and re-import within the same version.* The Settings Wizard can be found in the installation directory.

Benefit: Improved user-friendliness.

**hyperCAD*®-S settings cannot currently be exported/imported.

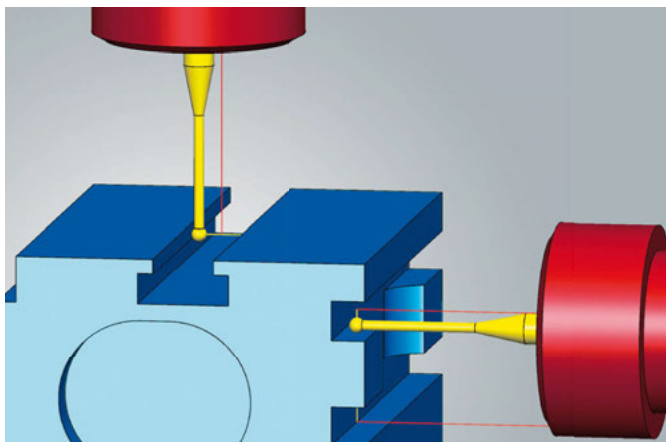

Highlight

Slot-Rib Probing

A new strategy makes it possible to measure slots and ribs using the familiar technology parameters. The area to be measured is defined by a simple contour selection. The strategy automatically determines the optimal measuring point.

Benefit: Improved probing functions.

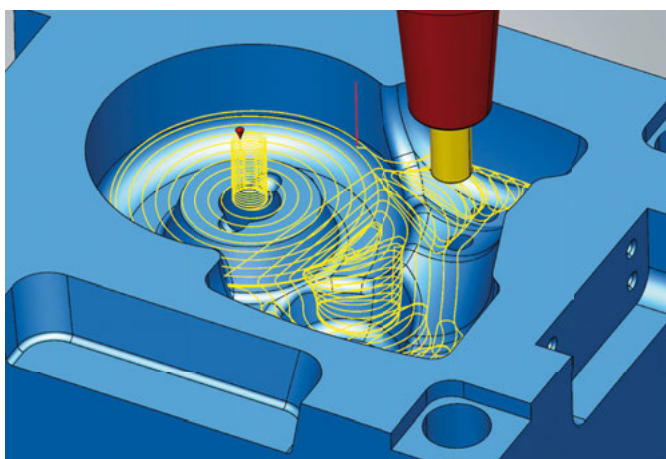

Highlight

3D Optimized Roughing

High-performance mode* is now also available in this strategy. The strategy also offers improved area sorting, resulting in fewer retractions. Areas in which a collision occurs are specifically excluded. In doing so, the collision check considers the tool including the shaft, extensions, and tool holder.

Benefit: HPC roughing is supported.

* High-performance mode supports the familiar *hyperMILL*® MAXX Machining technology for roughing. This generates spiral and trochoidal toolpaths and optimizes machining. High-performance cutting (HPC) is characterized by a very high stock removal rate.

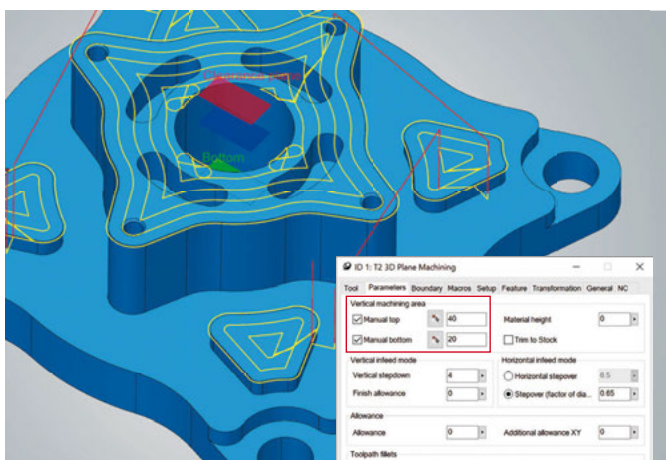

3D Plane Machining

The user can now define the machining area by surface and depth. This facilitates better control of machining and optimal tool utilization. A negative bottom allowance can now be defined for machining with end mills and bullnose end mills.

Benefit: Improved control over machining tolerances.

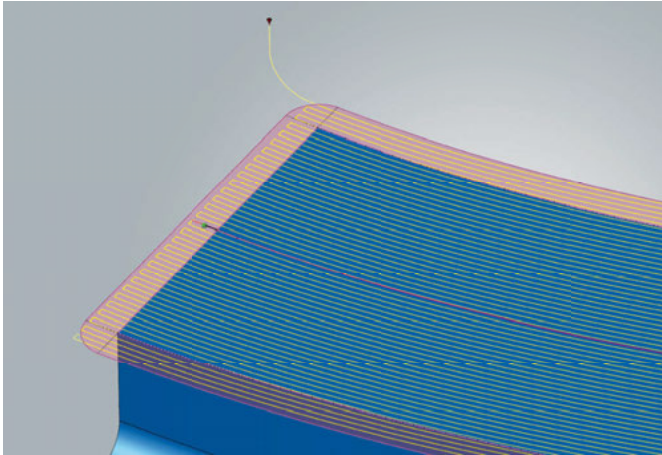

Highlight

3D Profile Finishing

Two new functions are available:

Automatic face extension

During programming, the 'Automatic face extension' function can be used to extend the circumference of selected milling surfaces. This CAD-for-CAM function eliminates the need to modify the milling faces in the CAD system beforehand.

Free tool geometry

Free tool geometry can now be used in 3D profile finishing. This makes it possible to use any tool types, such as high-feed cutters for example, for highly detailed programming and collision control.

Benefit: Increased user-friendliness, use of free tool geometries.

3D Equidistant Finishing

The 'Surface precision mode' option is available to further improve surface quality. In this mode, toolpaths are calculated using real component surfaces and not a faceted calculation model. This allows ultra-smooth surfaces to be produced.

Benefit: Improved surface quality.

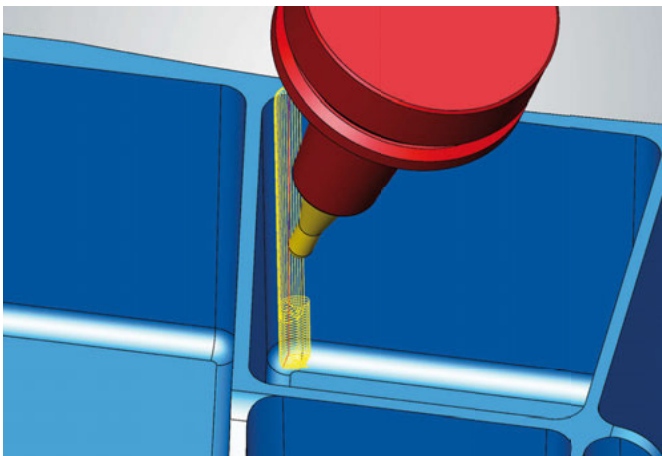

Highlight

3D- and 5-Axis Corner Rest Machining

This strategy merges optimized toolpaths for high-performance rest material removal in corners. Parallel and Z-level toolpaths ensure efficient rest machining. Optimized machining of floor areas is also possible. This means that the best method is applied in every situation.

5-Axis Corner Rest Machining makes indexed machining of difficult to reach corners possible. Automatic inclination selection, simultaneous linking movements, and collision avoidance are available in this process.

Benefit: Efficient rest material machining.

Highlight

Additive Manufacturing – It’s Only Truly Perfect with CAD/CAM

hyperMILL® ADDITIVE Manufacturing is a powerful solution for additive manufacturing and helps to take full advantage of this new and growing technology. It allows you to perfectly and flexibly control additive processes, and on many machines to control both additive and subtractive processes. Two methods have become established in the field of additive manufacturing – for Powder Bed Fusion (PBF) OPEN MIND is the ideal solution provider with its CAD/ CAM software which optimally integrates into the process chain to post-process printed parts.

Directed Energy Deposition

hyperMILL® ADDITIVE Manufacturing actively controls the material application of the Directed Energy Deposition (DED) process and thereby ensures optimal results. When additive and subtractive manufacturing are combined in a single machine tool, this is referred to as a hybrid manufacturing process. *hyperMILL*® enables users to perfectly program the cladding and the milling together. True-to-detail application and removal simulation as well as stock tracking between the individual machining steps guarantee the greatest possible process reliability.

■ Component creation

The build speed of the Direct Energy Deposition process is many times higher than the powder bed technology. The 5-axis simultaneous build process allows a user to manufacture complex parts even without support structures. The laser processing head is always optimally guided along the part

Base body structure
5-axis simultaneous build-up process

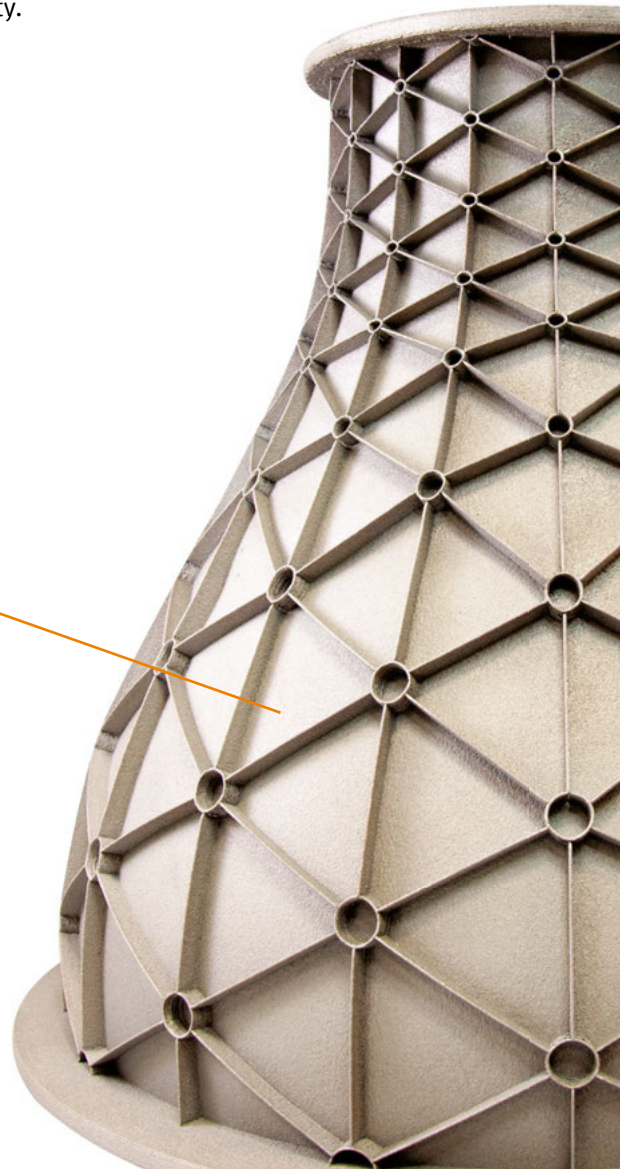
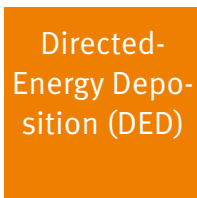

Features

- Flexible strategy for additive material application
- Various filling strategies for planes as well as free-form shapes
- Filling strategies for 2D and 3D sections
- 5-axis simultaneous application with optimal tilt strategies
- Full simulation of additive and subtractive processes, including material deposition
- One postprocessor for milling and/or additive processes
- CAD interface to all common CAD systems
- High level of laser configurability via technology parameters in the tool database

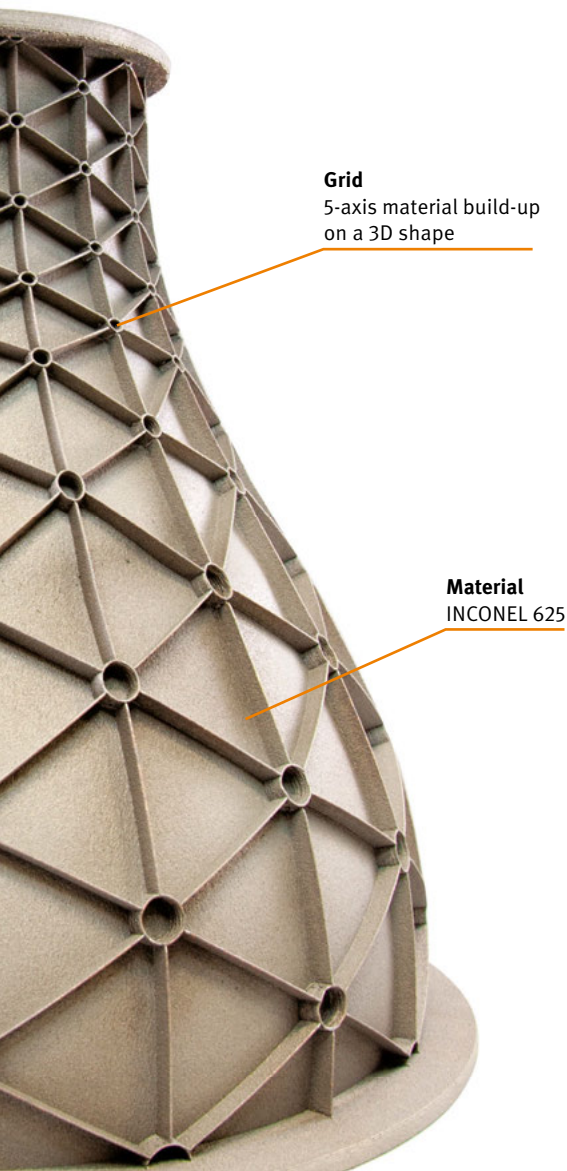

Turbine Blade Repair

Hybrid-machining of a damaged turbine blade. The defective area is milled off and then re-welded. In this process material is alternately added with a laser welding head and post-machined until the component geometry is completely restored.

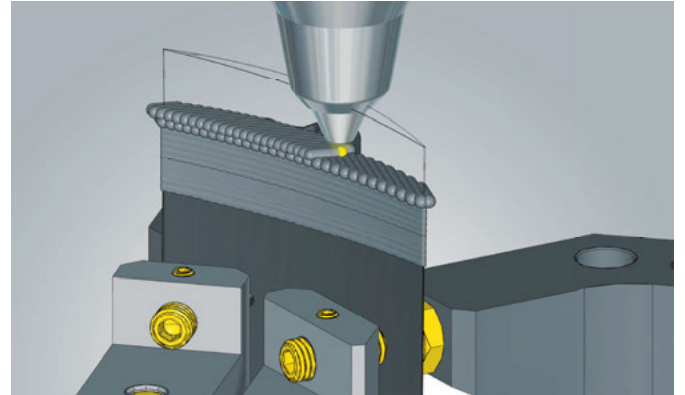

Additive Machining of an existing component

Material will be applied to change the component properties. In certain areas the thickness of the part is increased by laser deposition welding. Or in some cases a dissimilar material may be added for better engineering properties.

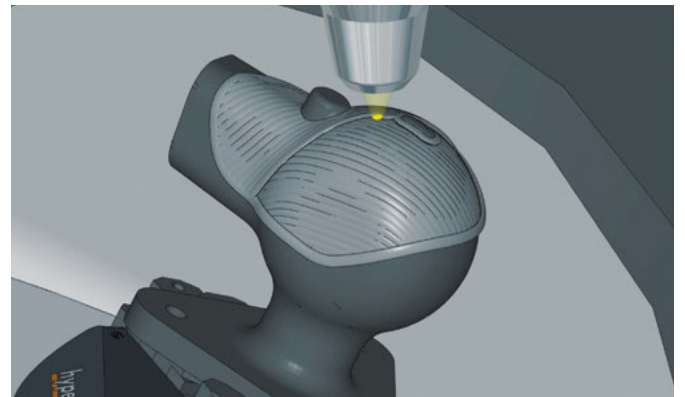

Collision Control and tool database

The laser processing head is modeled in detail in *hyperMILL*® and included in the collision check. The technology parameters of the laser processing head can be managed via the tool database. During the post-processor run the corresponding NC Code is then created along with all control commands.

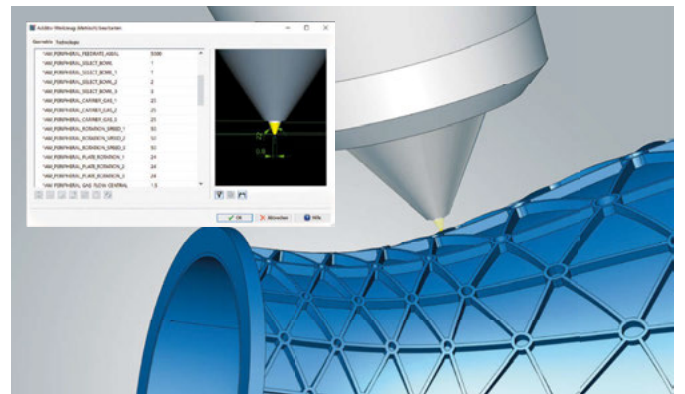

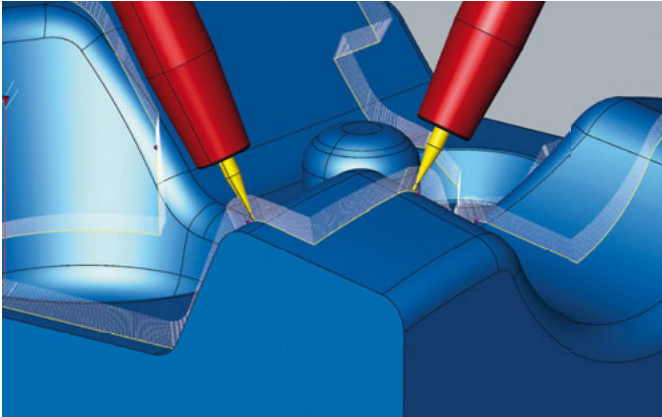

5-Axis Contouring

The strategy now offers further options to generate the tool inclination for 5-axis motion control optimization. In addition to 'Exact Mode', interpolation between the face normals is now also supported. The user benefits from safe machining with smoother machine movements.

Benefit: Safe and smooth machining.

CAM – 5-Axis Special Applications

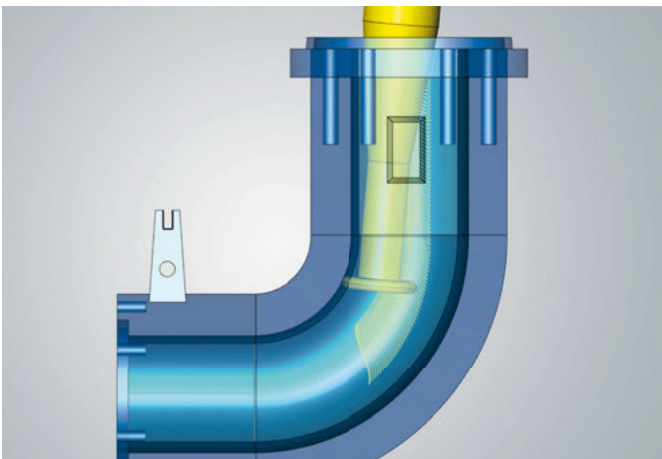

5-Axis Tube Finishing

Woodruff cutters can now also be used in this strategy. The tool cutting edge, shaft, and holder are included in collision control and avoidance. In addition, it is now possible to easily and precisely define the milling areas with fixed inclination and for 5-axis simultaneous machining.

Benefit: Machining of extremely undercut areas.

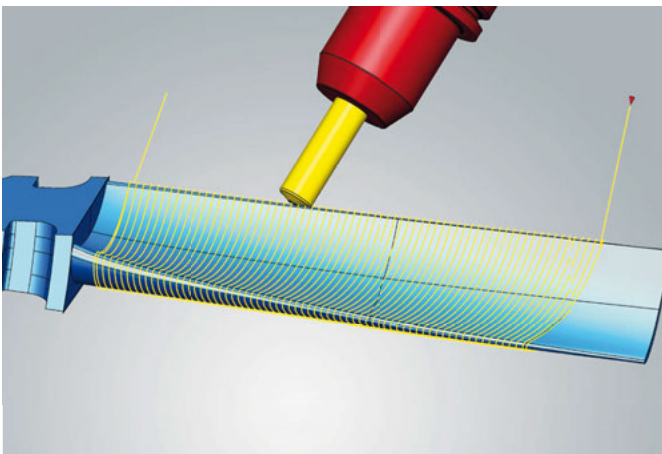

Highlight

5-Axis Blade Tangent Milling

This new strategy facilitates top milling of turbine blades using conical barrel cutters with a large conical angle. As a result, higher feedrates remain possible, while avoiding center-cutting. Large step-overs are possible with the conical barrel cutter and provide a fine surface finish.

Benefit: Increased efficiency, improved surface quality.

hyperMILL®

JIG Grinding

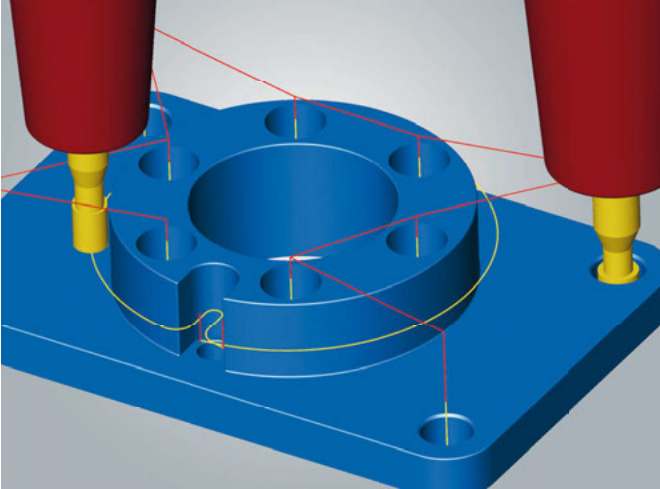

hyperMILL® JIG Grinding offers easy-to-program CAM strategies to create safe and reliable NC programs for vertical or conical chop grinding. *hyperMILL*® uses the machine tool's controller cycle and can be used on grinding machines but also on hybrid machines with grinding and HSC milling function.

Hole Grinding

Hole grinding is easy to program just like a drilling job. Thanks to *hyperMILL*® feature and macro technology it is possible to automate the programming of these grinding jobs.

2D Contour Grinding on 3D Model

2D contour grinding makes it possible to easily and safely machine workpieces along a contour. Users simply select the contours to be machined, and *hyperMILL*® automatically generates collision-checked toolpaths.

Benefit: Quick and easy programming of grinding processes.

Feature and Macro Technology

Macro – Compound Job

In order to better structure macros, individual compound jobs can be selected with their associated jobs when creating macros. The name of the compound job is saved with the macro, and can later also be run using this name.

Benefit: Improved clarity.

Feature – Close Pockets

Open pocket features can now be easily closed using a function in the feature list. This can be done automatically using the pocket geometry or by manually selecting a curve.

Benefit: Improved user-friendliness.

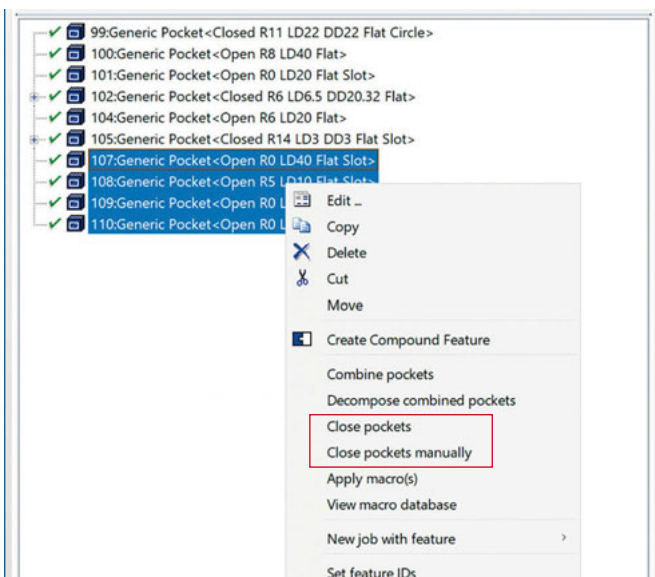

Parting

During parting, the selected contour is now automatically extended to match the respective stock model in order to simplify programming. The insert radius is taken into consideration, ensuring clean parting.

Benefit: Improved user-friendliness.

Highlight

Automatic Contour Feature Splitting

hyperMILL® jobs automatically determine the area to be machined based on the turning contour. The grooving job will automatically recognize if a contour is a groove, for example. This makes it faster and easier for the user to program certain areas.

Benefit: Simplified programming.

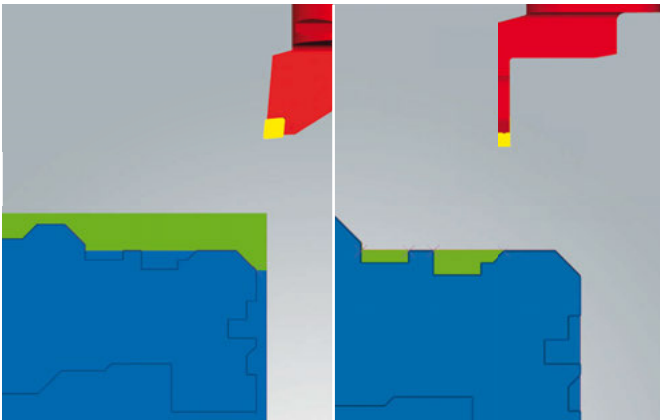

Finishing

Toolpaths for finishing can now be calculated without a selected stock model.

Benefit: Improved user-friendliness.

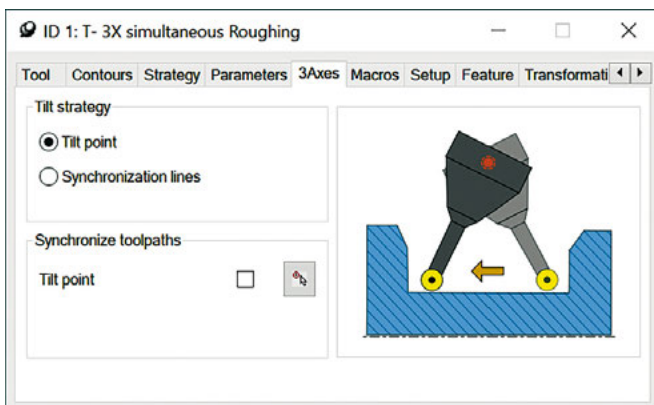

3-Axis Simultaneous Turning

In addition to control using synchronization lines, the tool can now also be controlled using a tilt point. In this process, the tool is fixed at a specific point and executes tilting movements on the third axis from this point. This method reduces programming effort while simultaneously increasing safety during simultaneous machining.

Benefit: Simplified programming.

Highlight

hyperMILL® AUTOMATION Center

The new *hyperMILL*® 2020.1 version allows users to automate joblist creation processes using the *hyperMILL*® AUTOMATION Center.

The *hyperMILL*® AUTOMATION Center is the foundation for further automation, and serves as both a development and runtime environment. This makes it possible to standardize and automate complex process workflows in *hyperCAD*® -S and *hyperMILL*®. The *hyperMILL*® AUTOMATION Center provides the toolkit for OPEN MIND's internal experts to provide comprehensive process automation, and is also available for end-users in a basic version.

The first expansion is included in *hyperMILL*® by default.* This allows you to automate the joblist creation process and the selection and positioning of the clamping device, as well as define a uniform process for all programmers. Users are also able to use standardized clamping devices during programming.

*Only available for *hyperMILL*® in *hyperCAD*®-S.

Features

- Comprehensive template functions
- Individually configurable
- Extended stock model options
- Clamping device management
- Documentation options for individual processes

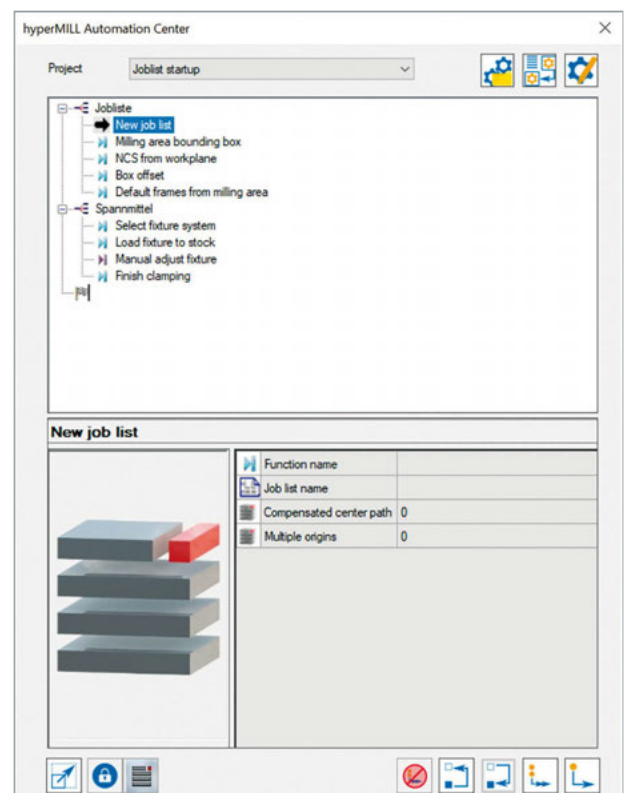

Perfect Fusion of the Virtual and Real Worlds

In today's manufacturing environments, virtual representations of real machines as so-called digital twins are becoming increasingly important. This is the only way of generating simulations that are true to reality, and makes it possible to design significantly more efficient and safe set-up processes.

hyperMILL® VIRTUAL Machining consists of three modules.

In the **Center, which is the simulation solution**, the machine, including controller and PLC, are represented virtually and simulated based on the NC code – for maximum safety.

During the postprocessor run, the **Optimizer** automatically selects the best solution for collision-free orientation. All traverse movements between the individual machining steps are optimally linked with one another.

CONNECTED Machining enables bidirectional networking with the machine. Parameters can be compared against the CAM programming, and the machine can also be controlled remotely.

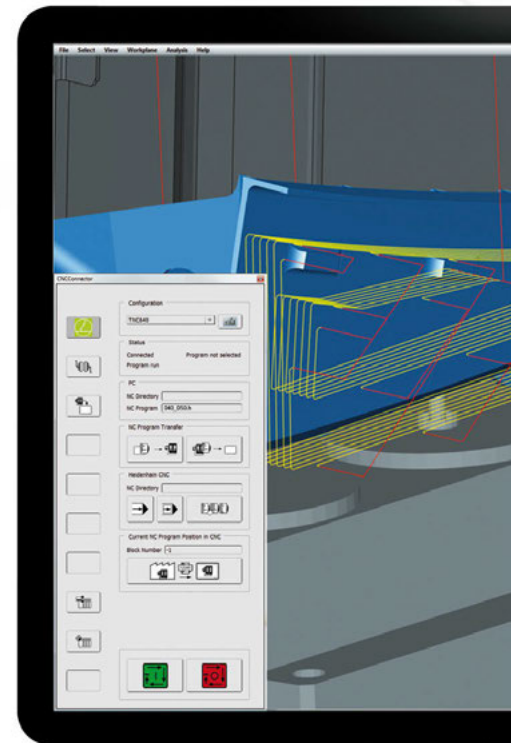

hyperMILL
VIRTUAL Machining

Center

Optimizer

hyperMILL
CONNECTED Machining

Application areas

- Checking, evaluating and optimizing the machining process
- Support for the acquisition of new machines
- Machine allocations
- Fast machine changes
- More accurate estimation of costs for bid proposals

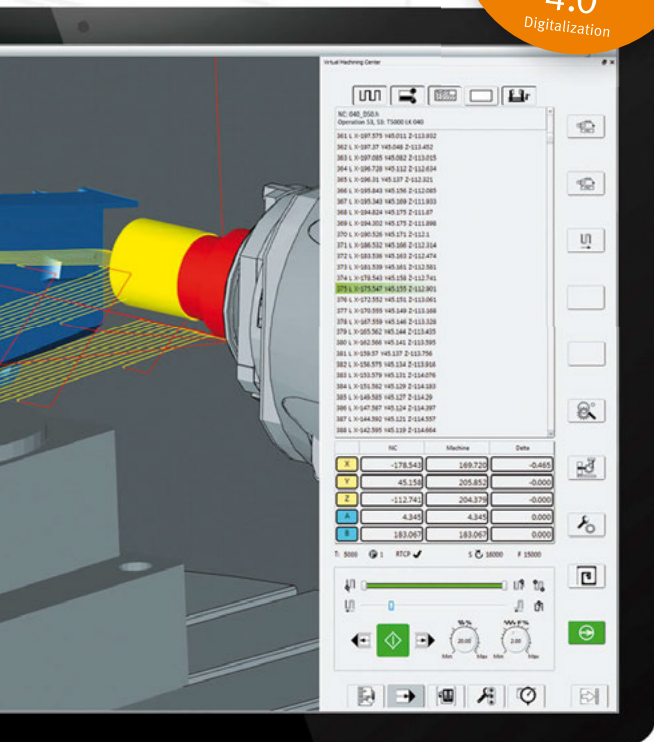

New Functions in 2020.1

Highlight

Optimizer

The Optimizer offers improved performance for automatic solution selection and the calculation time during the postprocessor run. In addition, settings for the preferred direction control and collision avoidance may be defined in each individual *hyperMILL*® job. This makes it possible to override the global settings in the machine definition.

The new 'Smooth linking' function automatically optimizes all linking movements between the individual operations during the postprocessor run. This ensures that repositioning and movement is always in close proximity to the workpiece and checked for collisions. Thanks to this function, programming using job linking is not necessary in *hyperMILL*®.

Benefit: Significant reduction in auxiliary processing times.

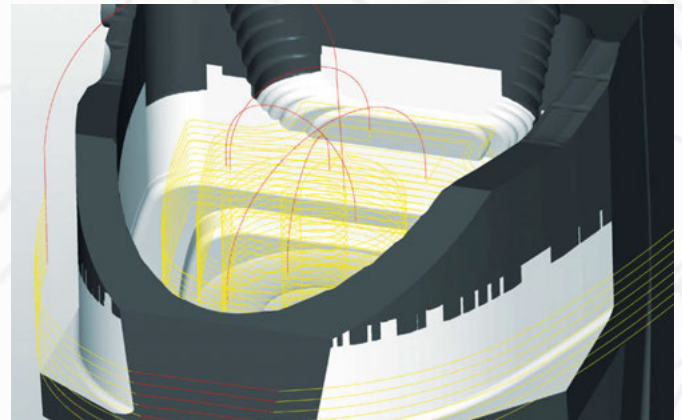

Center

New and improved functionalities extend the scope of the *hyperMILL*® VIRTUAL Machining Center simulation solution.

- Improved axis diagram display options
- Extended collision check options

CONNECTED Machining

Ongoing development of the module has improved user-friendliness and extended compatibility through the addition of new controllers.

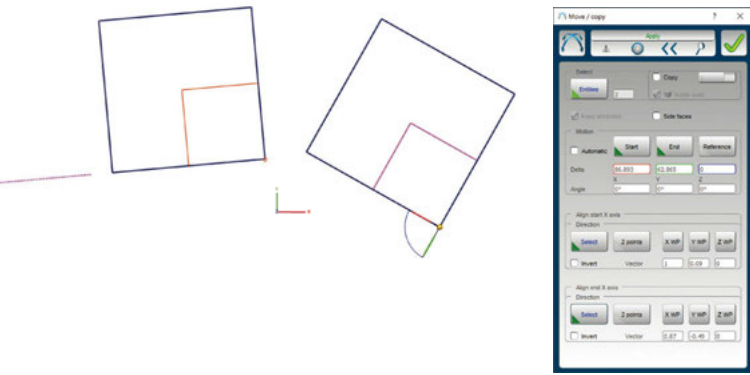

Move and Copy

End alignment when moving and copying elements can now be defined by selecting a line, individual points, or an axis.

Benefit: Moving elements is easier.

Highlight

Side electrodes

hyperCAD®-S now supports the creation of side electrodes. These are created in the same way as vertical electrodes, and defined using specific parameters such as axis, eroding depth, joint angle, or joint length. Collision checks optimize the parameters and protect against contact during approach.

Benefit: Simple side electrode creation.

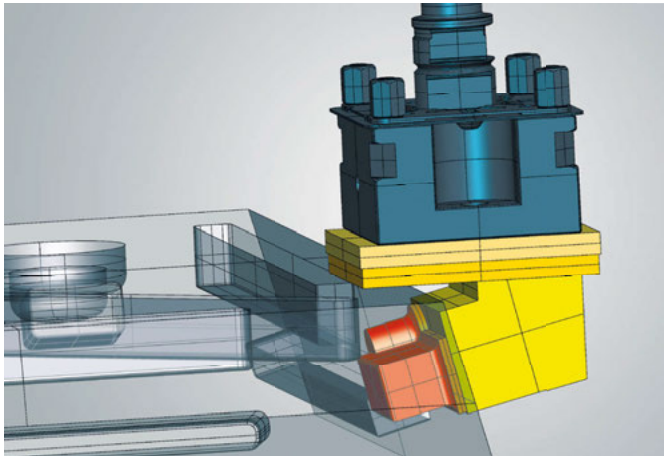

Highlight

Align faces orientation

The 'Align faces orientation' function makes it possible to automatically align all normals of a selected connected face area.

Benefit: Uniform face alignment.



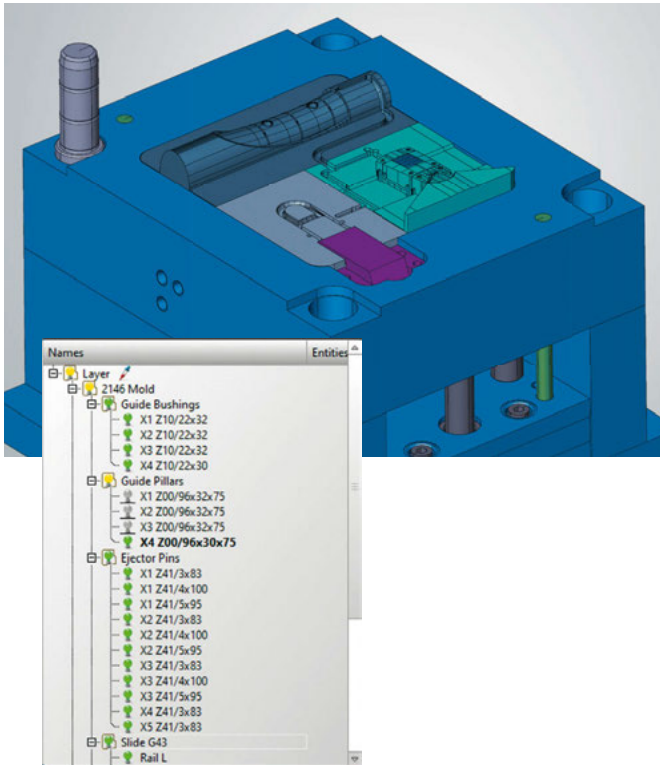

Layer Containers

So-called layer containers can be created to improve clarity. Individual layers can be combined into a group in the container, making it possible to control visibility at the global level. Individual layers can also be dragged in and out of the container.

Benefit: Greater clarity for layer display.

Layer Search

Full-text search is now available for layers and layer containers. This makes it possible to quickly find individual layers in complex layer structures.

Benefit: Improved user-friendliness.

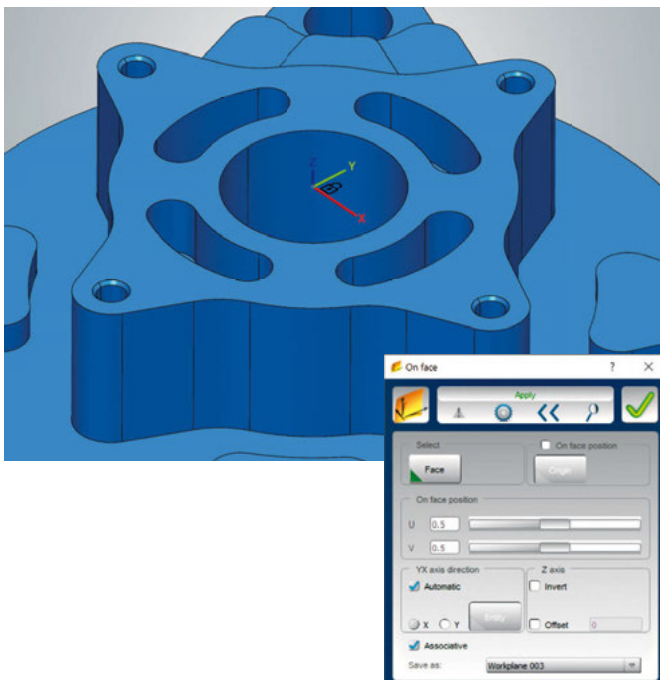

Associative Workplane

It is now possible to create an associative link between workplanes and elements. If the element is changed, the workplane will be updated.

Benefit: Improved user-friendliness.

- Headquarters** OPEN MIND Technologies AG
Argelsrieder Feld 5 • 82234 Wessling • Germany
Phone: +49 8153 933-500
E-mail: Info.Europe@openmind-tech.com
Support.Europe@openmind-tech.com
- UK** OPEN MIND Technologies UK Ltd.
Units 1 and 2 • Bicester Business Park
Telford Road • Bicester • Oxfordshire OX26 4LN • UK
Phone: +44 1869 290003
E-mail: Info.UK@openmind-tech.com
- USA** OPEN MIND Technologies USA, Inc.
1492 Highland Avenue, Unit 3 • Needham MA 02492 • USA
Phone: +1 888 516-1232
E-mail: Info.Americas@openmind-tech.com
- Brazil** OPEN MIND Tecnologia Brasil LTDA
Av. Andromeda, 885 SL2021
06473-000 • Alphaville Empresarial
Barueri • Sao Paulo • Brasil
Phone: +55 11 2424 8580
E-mail: Info.Brazil@openmind-tech.com
- Asia Pacific** OPEN MIND Technologies Asia Pacific Pte. Ltd.
33 Ubi Avenue 3 #06-32 • Vertex (Tower B)
Singapore 408868 • Singapore
Phone: +65 6742 95-56
E-mail: Info.Asia@openmind-tech.com
- China** OPEN MIND Technologies China Co. Ltd.
Suite 1608 • Zhong Rong International Plaza
No. 1088 South Pudong Road
Shanghai 200120 • China
Phone: +86 21 588765-72
E-mail: Info.China@openmind-tech.com
- India** OPEN MIND CAD/CAM Technologies India Pvt. Ltd.
#369/4, 1st Floor • 2nd Cross • 1st 'B' Main Road
7th Block, Jayanagar (W) Bangalore – 560070
Karnataka • India
Phone: +91 80 2676 6999
E-mail: Info.India@openmind-tech.com
- Japan** OPEN MIND Technologies Japan K.K.
Misumi Bldg. 3F • 1-17-18, Kichijojihigashicho
Musashino-shi • Tokyo 180-0002 • Japan
Phone: +81 422 23-5305
E-mail: info.jp@openmind-tech.co.jp
- Taiwan** OPEN MIND Technologies Taiwan Inc.
Rm. F, 4F., No.1, Yuandong Rd., Banqiao Dist.
New Taipei City 22063 • Taiwan
Phone: +886 2 2957-6898
E-mail: Info.Taiwan@openmind-tech.com

OPEN MIND Technologies AG is represented worldwide with own subsidiaries and through competent partners and is a member of the Mensch und Maschine technology group, www.mum.de



We push machining to the limit

www.openmind-tech.com