

# CoCreate® Sheet Metal

Streamline your sheet metal design and manufacturing

The CoCreate Sheet Metal add-on module is used by engineers in the high-tech electronics and machinery industry, satisfying the needs of even the most demanding sheet metal designers.

Create complex parts quickly and easily by taking the guesswork out of sheet metal design. Completed designs incorporate manufacturing process information, ensuring design for manufacturability (DFM) while shortening lead times with reduced scrap and material costs.

## Key Benefits

- Combine the speed of an explicit modeling approach to design with powerful sheet metal design features, enabling rapid iterations of product designs in build-to-order products
- Avoid the trial and error associated with traditional sheet metal design and manufacturing. Instead, use 3D CAD to simulate the complicated physical behaviors and material deformations from manufacturing processes. Your first prototype should be your only prototype
- Optimize product design to use industry-standard sheet metal tooling within the manufacturing process and eliminate unnecessary customized tooling costs.
- Bring your suppliers' custom sheet metal manufacturing capabilities into your 3D CAD software and expand your design options to include custom tooling available within your supply chain.
- Use 3D models and associated manufacturing data stored in sheet metal features to streamline the transition to production
- Calculate manufacturing costs in just minutes to provide fast and accurate bids for sheet metal projects to customers, or to support cost/benefit analysis for sheet metal capital equipment purchases

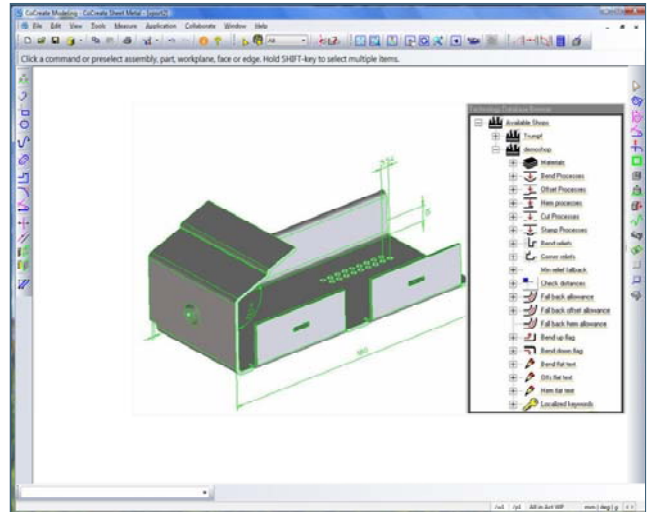

The Sheet Metal knowledge database with the manufacturing tools ensure the manufacturability of the design

## Features and Specifications

### Design Ready-to-Manufacture Sheet Metal Parts in 3D

- Sheet metal manufacturing know-how for your concept and detail design
- Optimized commands to create and modify sheet metal designs
- Bends, lips, hems, and offsets
- Punch and stamp
- Orthogonal side face cutting
- Automatic creation of reliefs and corner reliefs based on material and tool
- Intelligent creation of a sheet metal part from a solid model
  - Detection and assignment of sheet thickness
  - Assignment of bending information

### Design for Manufacturing

- Proactive design advice while modifying the part
- Automatic selection of preferred tools
- Design flaw detection and proposals for resolution, based on
  - Minimum distance from tool to existing bend, feature, or edge
  - Conformance of bend angles and radii to material and tool limits
  - Adequate size of corner reliefs
- Automatic model adaptation in response to changing material or manufacturing tooling/processes
  - Analysis for manufacturability with given shop data (tooling and processes)
  - Model adaptation to material thickness changes
  - Automatic detection and adjustment of bending information including bending reliefs
  - Detailed analysis report about conflicts and possible needed changes

### Ease of Use

- Reduces the number of interactions by factors

### Simulation

- Animated 3D folding and unfolding
- Automatic and manual selection of bends

### Accurate 2D Manufacturing Data

- Automatic generation of accurate and complete 2D flat drawing
- Recalculated dimensions reflecting material bend allowance values
- Tool identification codes for all punch and stamp operations, including position, direction, and angle
- Bend identification with tool and process information
- Bend and corner relief suppression/replacement
- Fully associative to 3D

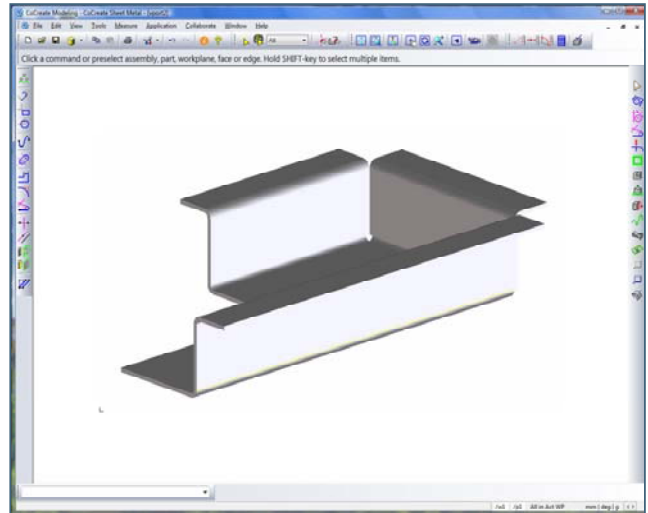

Sheet metal parts can be easily folded and unfolded with CoCreate Sheet Metal

### Cost Estimation

Based on

- Material and amount
- Number of operations and tools used
- Perimeter length and enclosing box size
- Surface finishes
- Fixing, such as rivets
- Lot size
- Set up, run, and handling time

### Technology Database

Maintains

- Sheet metal design expert knowledge
- Preferred materials
- Available tools
- Costing information

### Prerequisites

CoCreate Modeling

### System Requirements

CoCreate Sheet Metal supported operating systems:

- Windows Vista™ 32-bit and 64-bit Editions of Ultimate, Enterprise, and Business
- Windows® XP™ Professional 32-bit and 64-bit Editions

For more information, visit [www.ptc.com/products/cocreate](http://www.ptc.com/products/cocreate)

© 2008 Parametric Technology GmbH (a subsidiary of Parametric Technology Corporation). All Rights Reserved. Information described herein is furnished for informational use only, is subject to change without notice, and should not be construed as a guarantee, commitment, condition or offer by PTC. PTC, the PTC logotype, The Product Development Company, CoCreate and all PTC product names and logos are trademarks or registered trademarks of PTC and/or its subsidiaries in the United States and in other countries. All other product or company names are property of their respective owners.