



# hyperMILL®

2017.1

What's new?



**OPEN MIND**  
THE CAM FORCE

© The helmet was programmed and produced by OPEN MIND.



# What's new in 2017.1?

*hyperMILL*® 2017.1 means greater performance, more process reliability and increased flexibility. Significant auxiliary processing time savings can be achieved during mill turning with *hyperMILL*® *millTURN*-Linking. Numerous new functions for 2.5D, 3D and 5axis milling increase efficiency. These include 3D-optimised roughing and 5axis swarf cutting with a curve. The *hyperMILL*® MAXX Machining performance package has also been extended. And, *hyperCAD*®-S once again features many new highlights.

## Contents

### General

<b>Highlight</b> Freely definable tool cutting edge	3
<i>hyperMILL</i> ® Report	3
Global colour coding for toolpaths	3
Feature and macro technology	3

### *hyperMILL*® MAXX Machining

Overview	4
<b>Highlight</b> High-performance cutting (HPC)	6
5axis tangent machining	6

### CAM – 2,5D strategies

2D contour milling on 3D models	6
Cutter radius compensation	6
<b>Highlight</b> 2D T-slot milling on 3D models	7

### CAM – 3D strategies

<b>Highlight</b> 3D cutting edge machining	7
3D shape Z-level finishing	7
3D free path milling	7
<b>Highlight</b> 3D optimised roughing	8
3D arbitrary stock roughing	8

### CAM – 5AXIS strategies

<b>Highlight</b> 5axis swarf cutting with a curve	8
---------------------------------------------------	---

### CAM mill turning

<b>Highlight</b> <i>hyperMILL</i> ® <i>millTURN</i> -Linking	9
Chip break during roughing	9
Holder definition with ANSI/ISO parameters	9

### *hyperMILL*® VIRTUAL Machining

<b>Highlight</b> <i>hyperMILL</i> ® VIRTUAL Machining Center	10
--------------------------------------------------------------	----

### *hyperCAD*®-S: CAD for CAM

In a class of its own among CAD systems	12
-----------------------------------------	----

### CAD integration: *hyperCAD*®-S

<b>Highlight</b> Selection functions	13
TrueType fonts into NURBS	13
Swarf cutting faces	13
Variable filleting for faces	14
Linear sweep	14
Image CAD element	14
Export 3D PDF	14
<b>Highlight</b> Draft analysis	15
<b>Highlight</b> Curvature analysis	15
Polygons	15

**System requirements:** Windows® 7 (64-bit), Windows® 8.1 Pro and Windows® 10, DVD-capable drive

**CAD integrations:** *hyperCAD*®, *hyperCAD*®-S, Autodesk® Inventor®, SOLIDWORKS, ThinkDesign

**Software languages:** de, en, es, fr, it, nl, cs, pl, ru, sl, pt-br, ja, ko, zh-cn, zh-tw

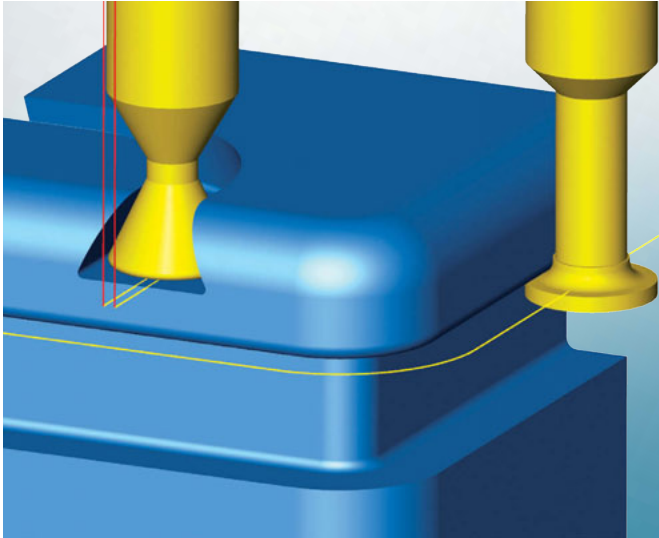

### Highlight

## Freely definable tool cutting edge

This extension allows freely definable tool geometries to be used for machining in selected 2D cycles. *hyperMILL*<sup>®</sup> uses the free geometries of the tool cutting edge for simulation and collision checking.

Suitable for the following 2D strategies:

- Contour milling on 3D models
- Playback milling
- Plunge milling

**Benefit:** Flexible tool definition, increased safety during collision checking, use of special tools.

NC Tools: 2nd Setup 27.09.2016

**OPEN MIND**  
THE CAM FORCE

NC-Tool: T20 TF D42 R6  
 Comment: 151  
 Comment: 89.45  
 Max. Infeed of tool: 95.6

Coupling type	Name	Tool length/Length compensation
Holder	HSK63	
Extension		0
Tool	T20 TF D42 R6	43.00

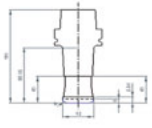

Tool: T032 TF D42 R6 ET090

Name	Corner radius	6
Diameter	Length	43
Shank diameter	Cutting length	6
Tip length	Chamfer length	
Cone angle	Spindle orientation	clockwise

Material	IS (m)	FX	FZ
T 2358	1800	4500	4250

Holder: HSK63  
 Comment: Clamp with 6Nm

Extension:  
 Comment:

NC Tools 2.M2

## *hyperMILL*<sup>®</sup> Report

Production reports with tool data and statistical data such as running time and path length can be created directly from *hyperMILL*<sup>®</sup> with this new function.

**Benefit:** Production reports are easier to generate.

## Global colour coding for toolpaths

The user can now control the colour coding of toolpaths locally or globally. Individual colour specifications are also possible.

**Benefit:** Improved visibility of toolpaths.

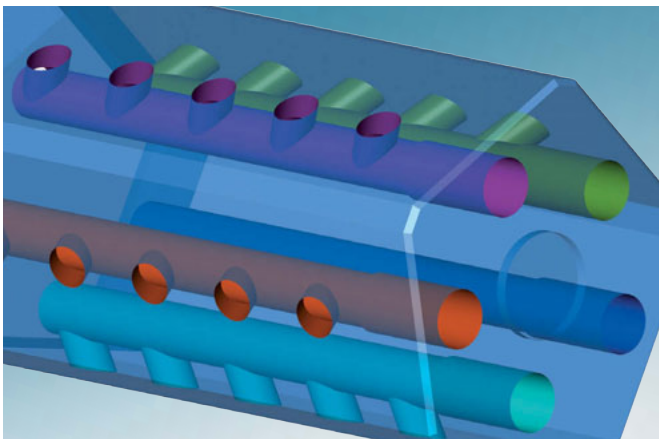

## Feature and macro technology

Features can now also be saved in a job macro. When the macro is used again, the feature information can be updated more quickly via filter assignments.

Individual cross-holes or all cross-holes in a chain can be grouped interactively in the Feature browser. This makes it possible to machine drill holes with associated cross-holes more easily and clearly.

**Benefit:** Reduced programming times, increased flexibility.

# Performance, Performance, Performance

Speed is more crucial than ever these days. This is why OPEN MIND developed *hyperMILL*® MAXX Machining, the comprehensive high-performance solution for roughing, finishing and drilling. Trochoidal tool paths ensure extremely fast material removal. Innovative strategies for barrel cutters allow for finishing in record time. Milling tools tilted in the cutting direction can quickly and easily drill holes and open pockets in hard material without the need for a predrilled hole.

These unique solutions from OPEN MIND save enormous amounts of time while ensuring the same high quality. This allows CAM programmers to maximise machine performance for any application.

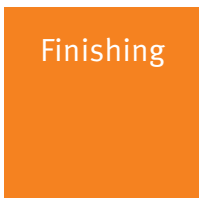
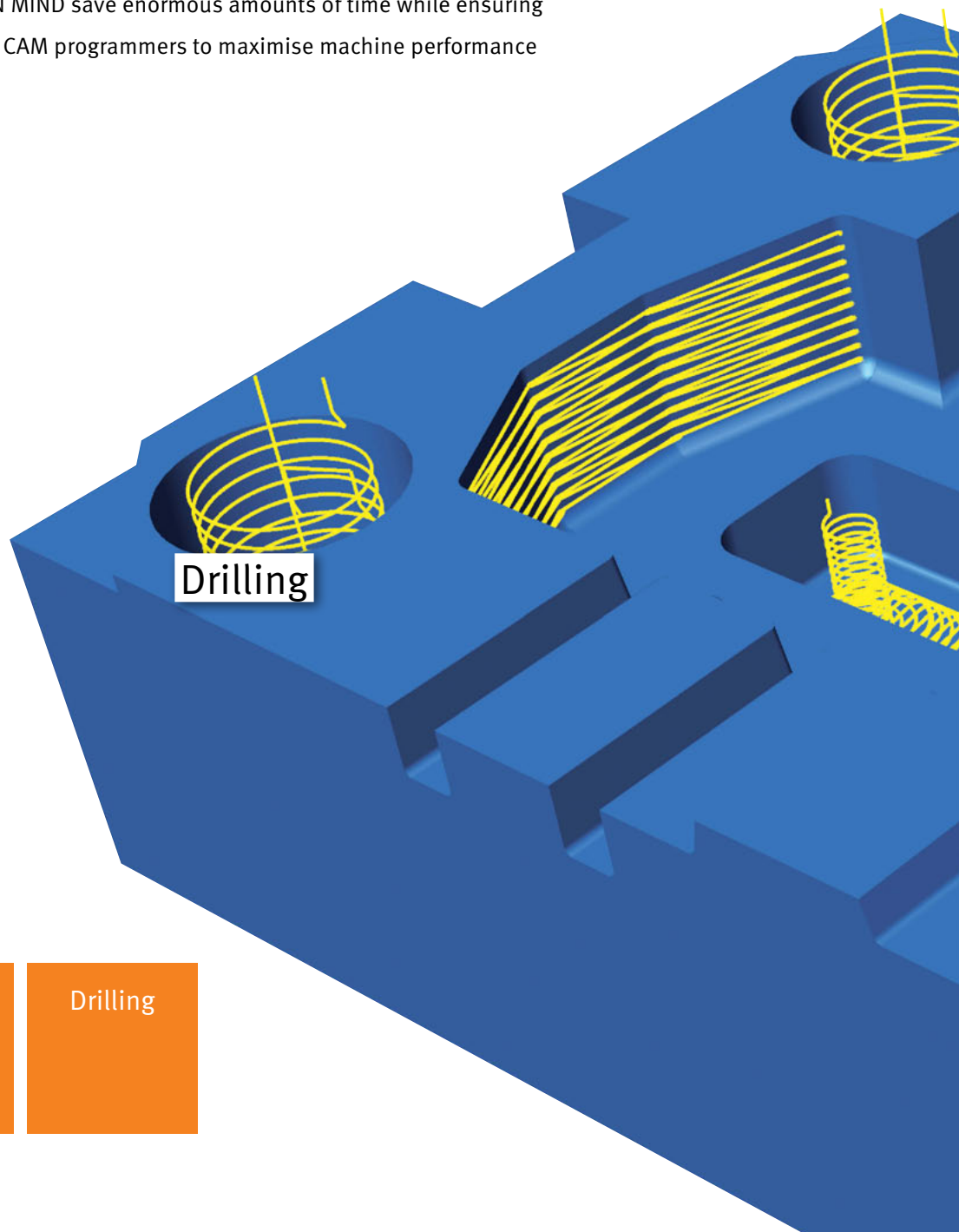

# hyperMILL<sup>®</sup>

## MAXX Machining

### ADVANTAGES

- Highly efficient
- Perfect surfaces
- Tool friendly
- Simple to program

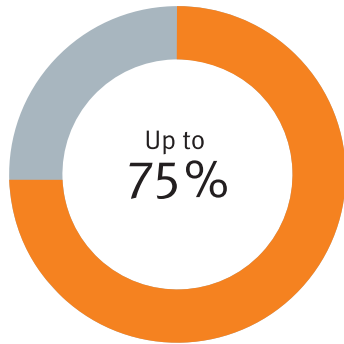

Time savings  
for roughing

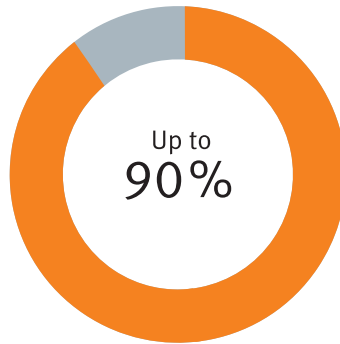

Time savings  
for finishing

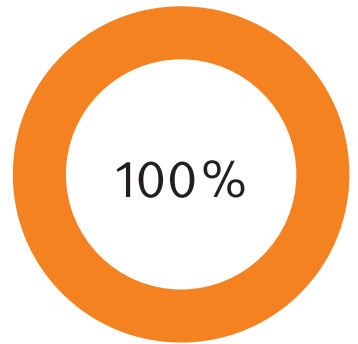

Process safety

### POSSIBLE APPLICATIONS:

- Tool and mould manufacturing
- Production Machining
- Aerospace
- Automotive
- Motor sports
- Energy industries

Finishing

Roughing

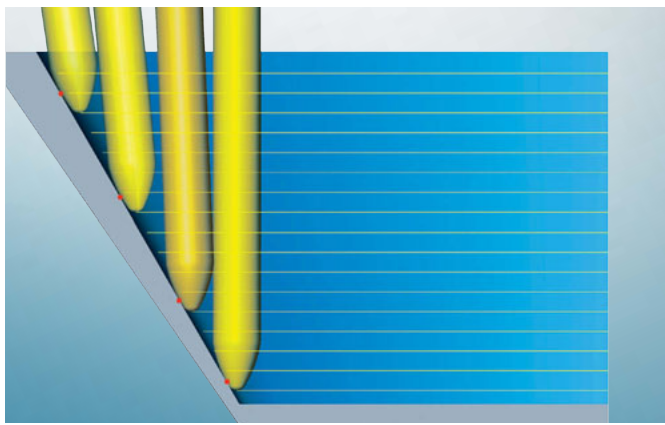
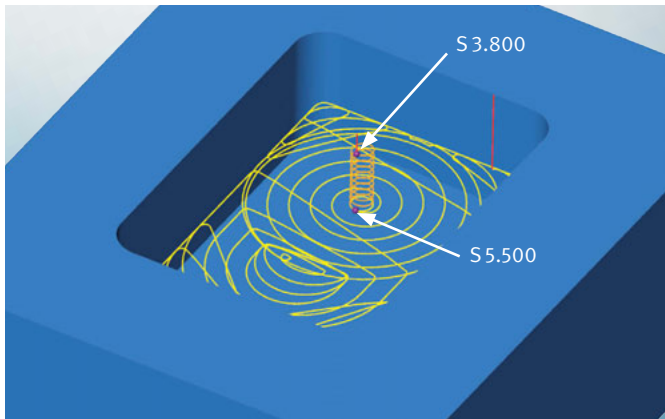

**Highlight**

## High-performance cutting (HPC)

A new option allows the spindle speed to be adjusted in the plunge macro for roughing. Modifying the spindle speed and specifying a dwell time for the speed change ensures more tool-friendly machining. This option is available for all roughing jobs in the 2.5D, 3D and 5axis area.

**Benefit:** Tool-friendly, greater process reliability.

## 5axis tangent machining

Three new options ensure better machining. A preliminary finishing step with an offset can now be defined for machining thin-walled planes. The 'Dynamic contact point' option is used to specify an area of the barrel radius for machining. This provides better control of how the barrel cutter nestles against the surface. The 'Global alignment' option has been added to the strategy for ISO machining. This allows the toolpaths to be calculated efficiently for a multiple selection of connected surfaces.

**Benefit:** User-friendly, simple programming.

## CAM - 2.5D strategies

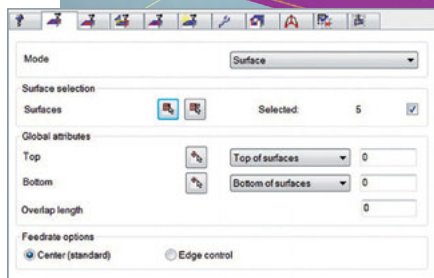
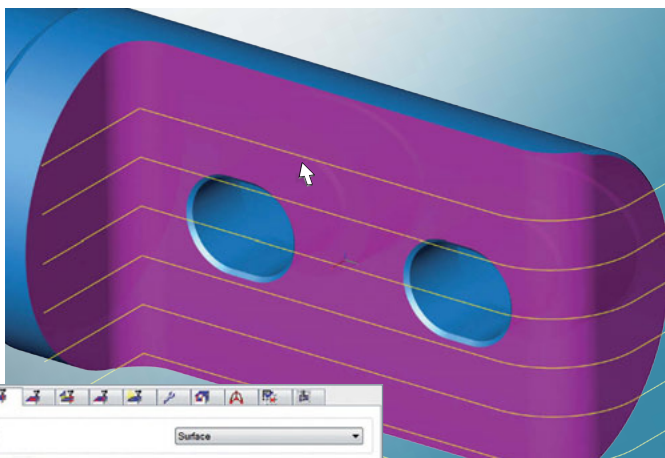

## 2D contour milling on 3D models

The milling contour is generated automatically by selecting perpendicular surfaces. The machining height and depth are transferred automatically from the surface information. The 'Contour surfaces' feature is also available for this new function.

**Benefit:** Simple and fast programming.

## Cutter radius compensation

Cutter radius compensation is available for the following 2D strategies:

- 2D thread milling
- 2D helical drilling

The 'Compensated path' and 'Compensated centre path' options allow the user to influence the cutter radius compensation directly via the machine controller.

**Benefit:** Simple programming and user-friendly.

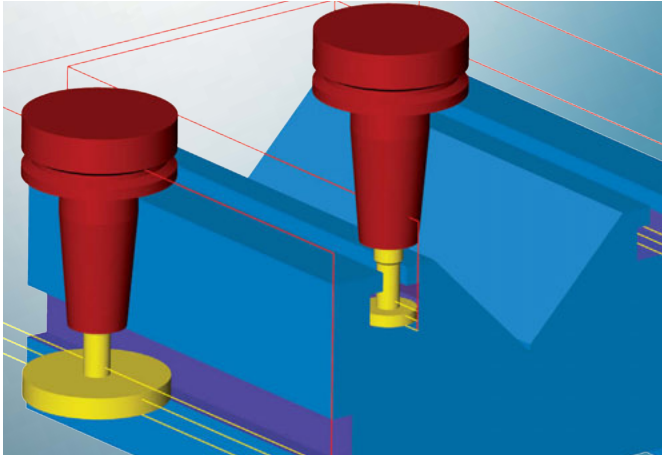
**Highlight****2D T-slot milling on 3D models**

This is a new strategy for the efficient machining of T-slots. Various tool references and an optimised axial infeed allow T-slots to be machined safely. All toolpaths are checked for collisions and therefore provide maximum safety.

**Benefit:** Fast machining of T-slots, user-friendly.

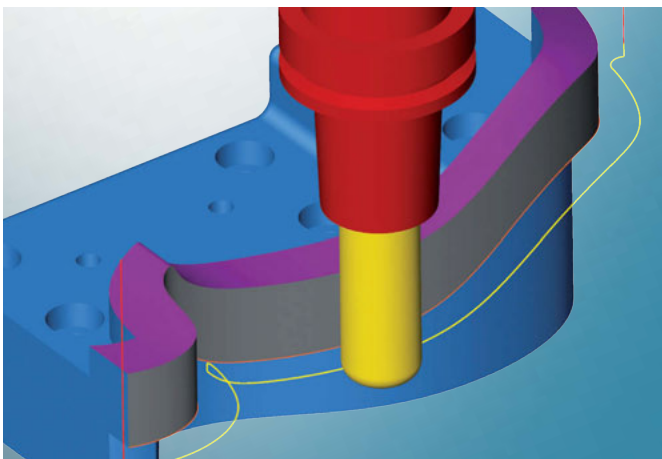
**Highlight****3D cutting edge machining**

This is a new cycle for the optimised 3D machining of cutting edges. Roughing and finishing operations are generated via a 3D curve selection. The rest material machining is generated via the 'Reference job' option. Here, the rest material areas of the previous machining operation are also included in each case. Toolpath smoothing ensures a better milling result if the contours are of poor quality. This strategy guarantees efficient machining, particularly for cutting dies.

**Benefit:** Fast and easy programming of cutting edges.

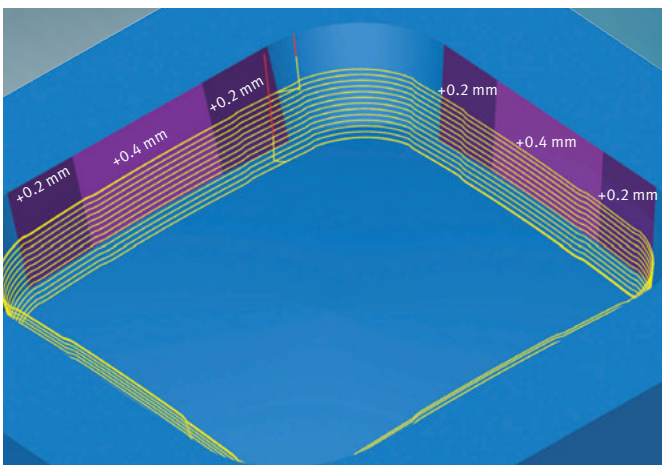
**3D shape Z-level finishing**

An extension allows multiple allowances to be defined. The strategy recognises the different allowances of the milling area and adapts the machining accordingly.

**Benefit:** Fast and easy programming.

**3D Free path milling**

Two new extensions in this strategy allow automatic path compensation and the definition of check tolerances to prevent unnecessary retraction movements in steep areas.

**Benefit:** Fast and easy programming.

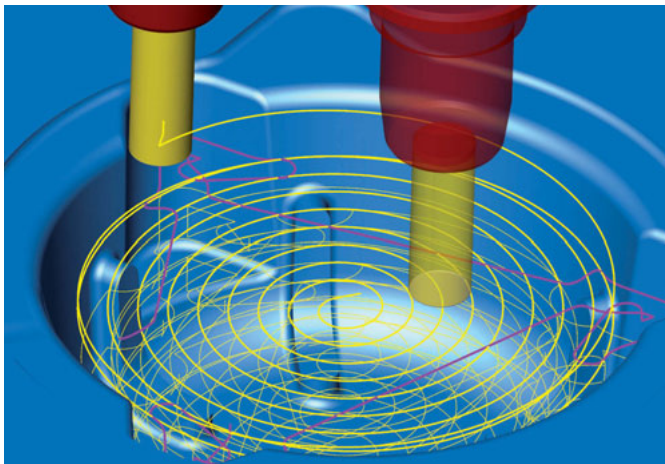
**Highlight****3D optimised roughing: adaptive pocket**

With the help of this extension, adaptive pockets are fitted into the area to be roughed. As a result, high feedrate cutters can be used more efficiently and the linear machine movements allow higher feedrate values to be achieved than before. The machining can be executed as an adaptive pocket or as an adaptive pocket in combination with conventional roughing. Here, the toolpaths of the adaptive pocket and the remaining machining are optimally connected.

**Benefit:** Simple and fast programming, fast milling.

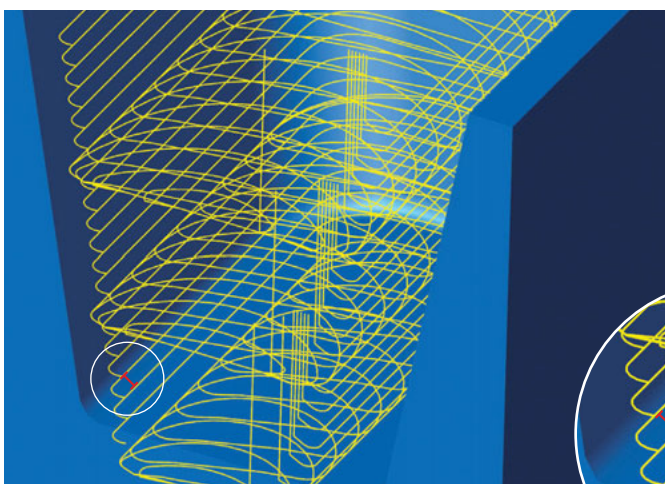
**3D arbitrary stock roughing**

Thanks to the addition of the 'Maximum step height' parameter, the vertical stepdown can now be divided equally over the entire machining depth. This makes it easier to control the step height during roughing.

**Benefit:** Simple programming, fast machining.

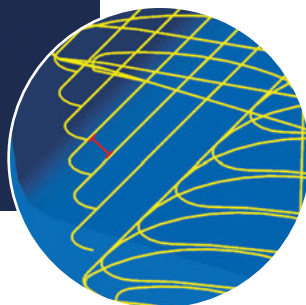

**Maximum  
step height**

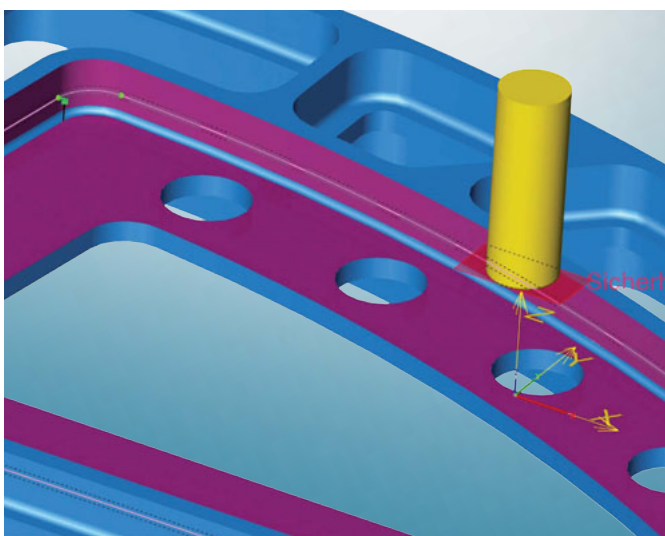
**Highlight****5axis swarf cutting with a curve**

Two new functions ensure greater user-friendliness. A perfect surface and an equally perfect curve are created automatically for swarf cutting based on selected geometries via a surface selection. Interior corners are filleted automatically. This ensures optimal machining.

**Benefit:** User-friendly, fast and easy programming.

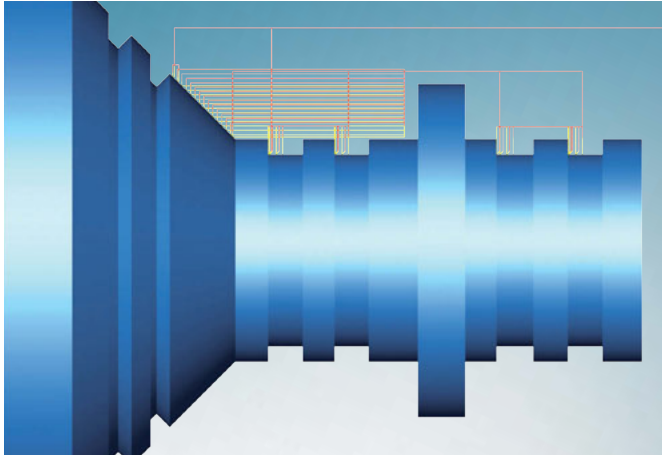

**Highlight****hyperMILL® millTURN-Linking**

hyperMILL® millTURN-Linking allows multiple job steps, which can be machined with the same tool, to be combined intelligently into a single job step. This eliminates retraction movements between the individual operations and significantly reduces auxiliary processing times. All connecting paths are optimised with respect to the component and checked for collisions.

**Benefit:** Reduced auxiliary processing times.

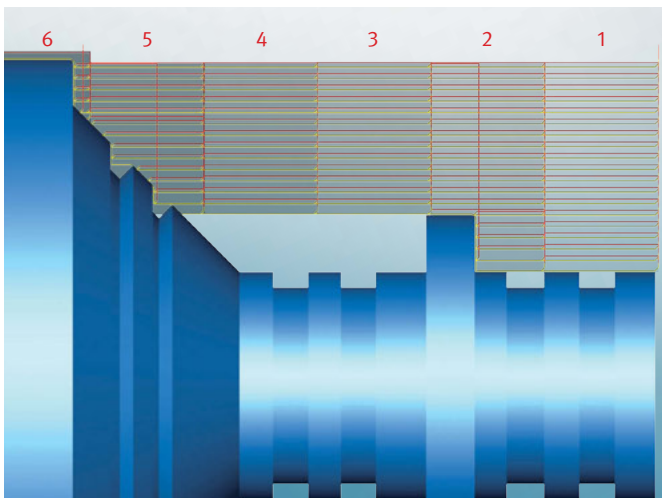
**Chip break during roughing**

This extended function allows the user to machine hard and soft materials more flexibly than before. The 'Chip break' option makes it possible to remove chips safely. For non-falling contours, the machining length can be defined in combination with a short stop. The user can choose between two methods to specify the stop and either define the dwell time or the number of spindle rotations.

In addition, another function helps to improve the control of the chip break. The 'Section size' option allows the user to divide the area to be machined into multiple sections. These sections are then machined in the specified sequence.

**Benefit:** Safe removal of chips, process reliability (workpiece surface is not damaged as the chip does not wrap around the spindle).

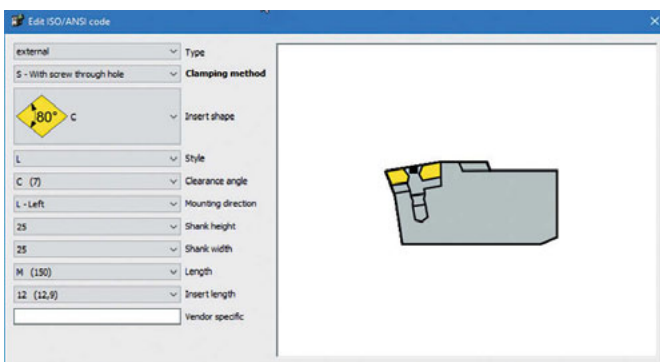
**Holder definition with ANSI/ISO parameters**

Holders can be defined in the tool database using ANSI/ISO code. This makes it easier to create standardised tool holders with the help of standard specifications.

**Benefit:** Fast and simple tool definition.

**Highlight**

# Perfect fusion of virtual and real machining

Real machine collisions not only cause damage to machines; they also lead to production losses and associated time delays. This is why the actual machining situation, that is, the machine including controller and PLC, is mapped virtually and simulated based on the NC code in the *hyperMILL® VIRTUAL Machining Center*. In addition, the innovative *hyperMILL® VIRTUAL Machining Connector* provides in-depth, unique networking and synchronisation with the machine.

## Reliable and comprehensive simulation

Often, machine movements are only simulated on the basis of internally used data. In other words, simulation takes place before the postprocessor run. In this type of CAM-based simulation, the postprocessor and simulation remain unconnected. With its *hyperMILL® VIRTUAL Machining Center*, OPEN MIND has decided to go one major step further by ensuring that the simulation is based on the NC code after the postprocessor run.\* Here, the virtual machine movements correspond exactly to the real machine movements. Only this machine simulation based on the NC code can guarantee reliable collision detection – even before starting on the machine.

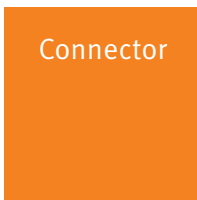
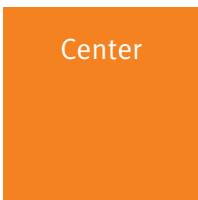
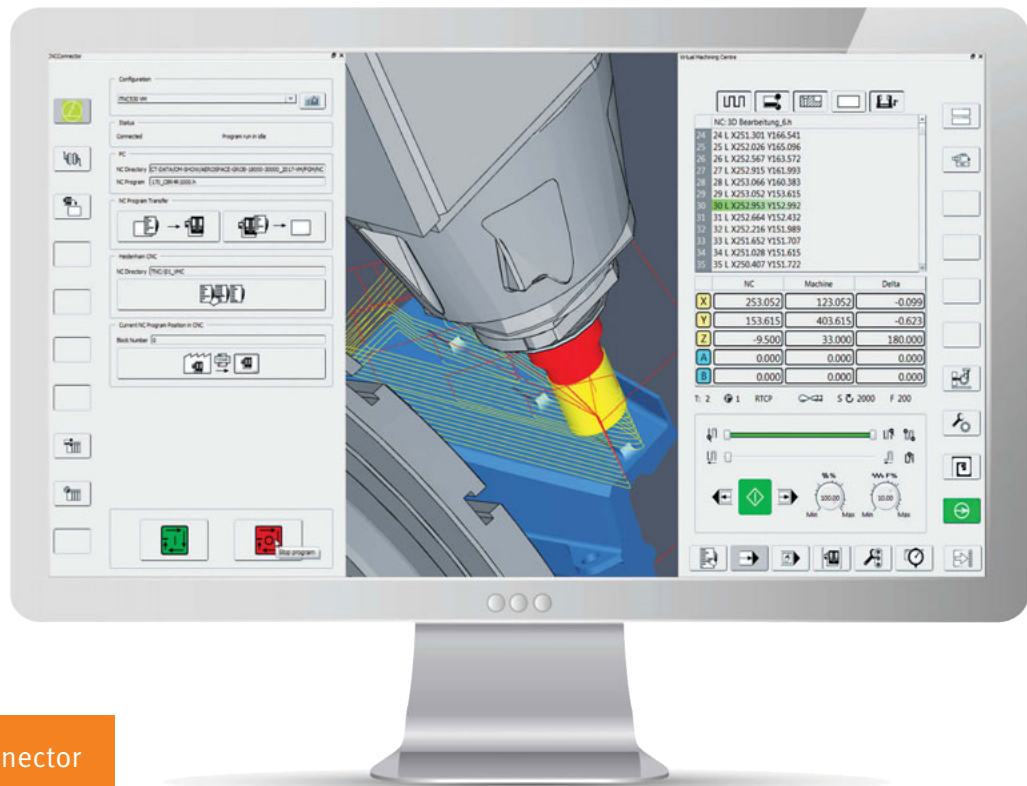

\*hyperMILL® VIRTUAL Machining requires a hyperMILL® Virtual Machining postprocessor.

## Networking in real time

Machines are opening up as Smart Factory advances. With its *hyperMILL*® VIRTUAL Machining Connector, OPEN MIND is for the first time offering a bidirectional exchange of data with the machine controller. This way, the CAM and machine world are networked in the best possible way and so-called 'Connected Machining' becomes a reality – an absolute highlight. Extensive advantages are opened up to companies on this new level of industrial digitalisation to secure long-term improvements in their processes and products.

## *hyperMILL*® VIRTUAL Machining – Making Smart Factory easy

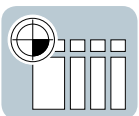

### Zero point alignment with the real machine

The machine zero points are aligned with those of the NC program. Clamping errors or incorrect positions are avoided.

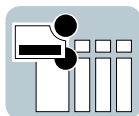

### Automatic tool comparison

Tool data from the NC program is automatically compared with the tool data of the machine. If this data does not match, an error message is output and the program run is halted.

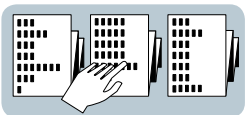

### NC block synchronisation

The NC block of the machine can be synchronised with the *hyperMILL*® VIRTUAL Machining Center; the machining position of the machine simulation after the synchronisation corresponds exactly to the real machine position.

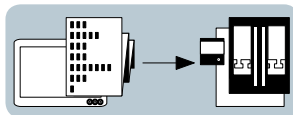

### NC program transfer

The NC program is loaded directly into the memory of the machine controller.

## Features

- Highest level of process reliability
- Avoidance of machine and tool damage
- More efficient lead-in processes thanks to early and reliable simulation
- The simulation is based on the NC code and also linked to the programmed manufacturing operations
- Readout of zero point definitions, tool data and critical machine parameters from the controller including a comparison with requirements of the NC program
- Networking and synchronisation of the NC block of the machine with the simulation

### ■ Simulation

The machine simulation and collision check for a defined machine model take into account not only the workpiece, tool and tool holder, fixtures and clamps, but also the controller and PLC. Component lead-ins are carried out true to detail in *hyperMILL*® VIRTUAL Machining Center.

### ■ Avoidance of operating errors

The NC program can only be transferred to the machine and started once the machine parameters, tool and zero point data match and a collision check has been carried out successfully.

### ■ Remote control of CNC machines

Perfect interaction with the machine via laptop or PC. Networking is also possible from the home office. The *hyperMILL*® VIRTUAL Machining Connector can be used to start or stop a program or perform difficult 'retract movements'.

### ■ Protected NC programs

NC programs are loaded directly into the memory of the controller and not into the hard drive this helps to prevent mistakes with the program selection. In addition, the data is protected against unauthorized access. This is an important aspect, particularly for aerospace certification processes.

**CAD for CAM**

# In a class of its own among CAD systems

Only a high-end CAM developer can do CAD for CAM. With this in mind, OPEN MIND Technologies AG – known as an innovative pioneer – developed a new CAD system from scratch that is perfectly matched to *hyperMILL*®. The system has its own 3D CAD kernel made by OPEN MIND. The result is a unique CAD system for CAM programmers that is very easy to learn and that vastly accelerates NC programming processes.

*hyperCAD*®-S fully exploits the performance offered by contemporary hardware systems to create digital manufacturing data. The advanced and extremely powerful 64-bit system is the perfect solution for mastering many of the daily challenges that arise when working with meshes, faces and solids to create precise components and tools. Large volumes of imported data can be prepared for subsequent NC programming easily, quickly, reliably and completely independently from the original CAD system. *hyperCAD*®-S is 'CAD for CAM' at its purest.

# hyperCAD<sup>®</sup><sub>S</sub>

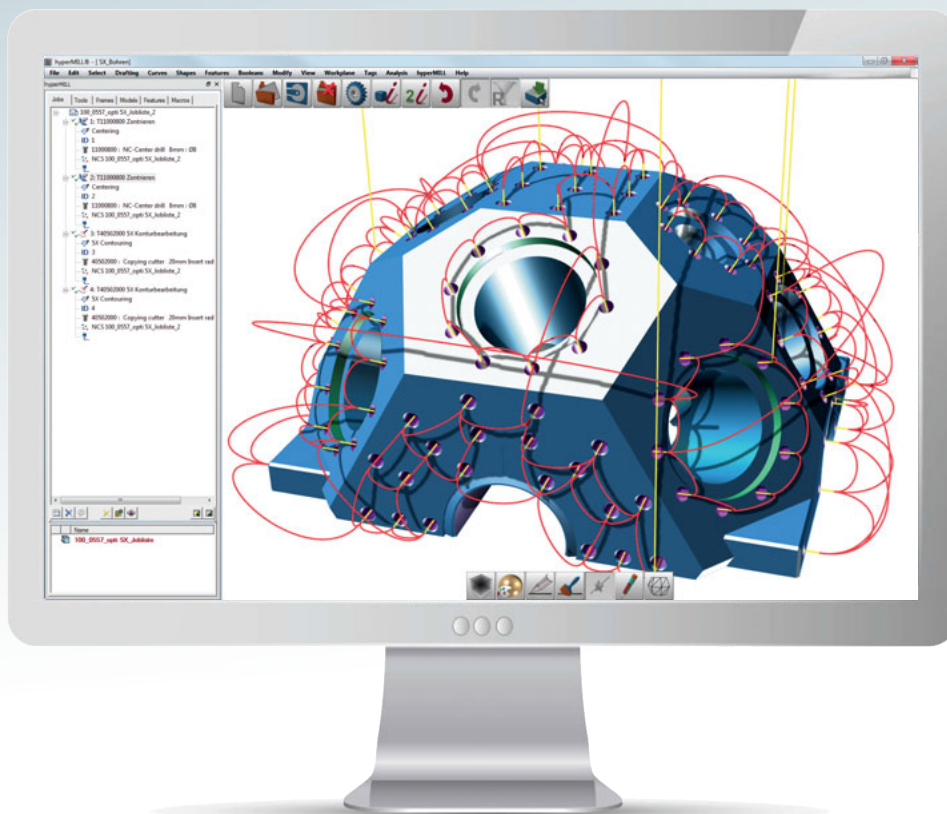

- CAD for CAM
- 64-bit multi-application
- Top performance
- Optimal ergonomics
- Highly intuitive
- Optimal hardware utilisation

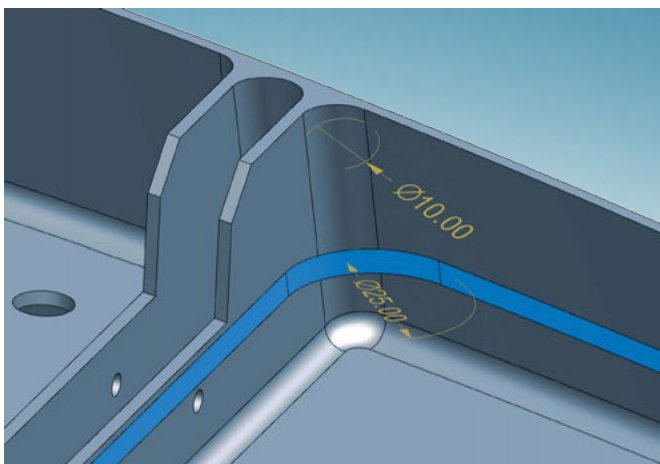
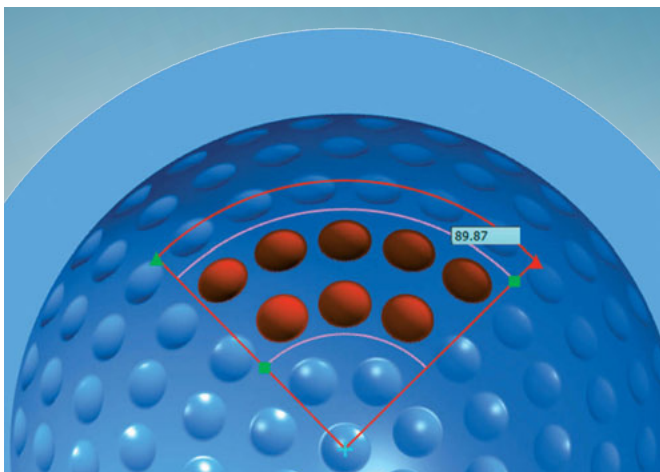
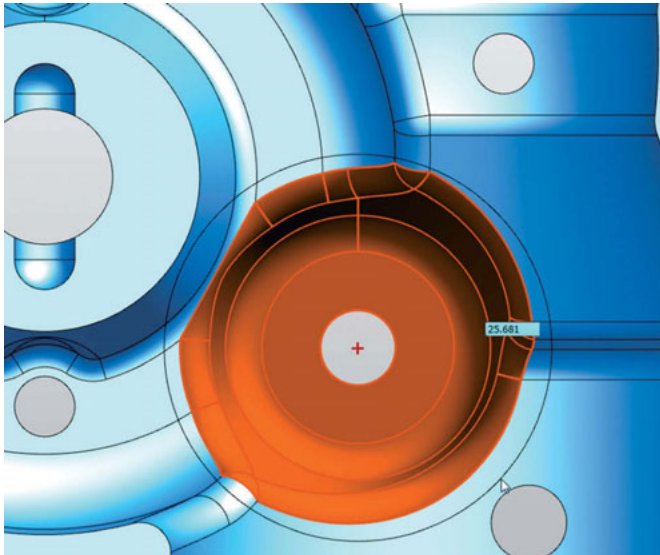

### Highlight

## Selection functions

Two new functions and an optimisation are available for selecting CAD elements.

- **Circular selection:** a new selection tool for selecting circular CAD elements
- **Segment selection:** This new selection tool makes it possible to select CAD elements in segment areas.
- **Limited faces:** This command allows a selected chain to be used as a boundary.

**Benefit:** User-friendly.

## TrueType fonts into NURBS

TrueType fonts can be converted into NURBS curves to achieve a better milling result..

**Benefit:** Optimised milling contours for engraving.

## Swarf cutting faces

An extension ensures that the swarf cutting face is automatically and variably adapted on the basis of the tool diameter when different component radii exist.

**Benefit:** User-friendly.

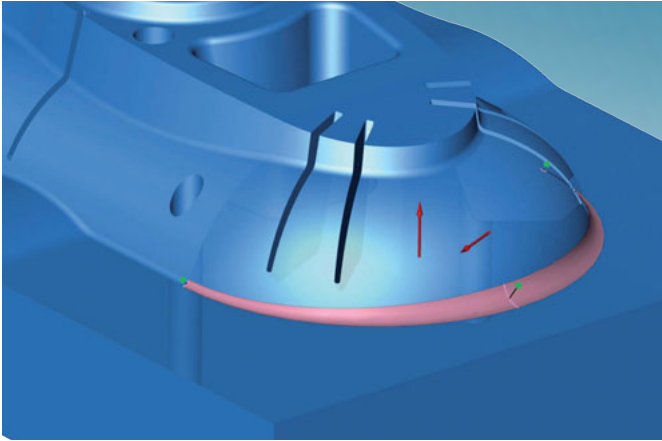

## Variable filleting for faces

This extension allows the start and end radii of face-to-face fillets to be variably defined. The user can choose the linear or parabolic mode.

**Benefit:** Simple definition of variable fillets.

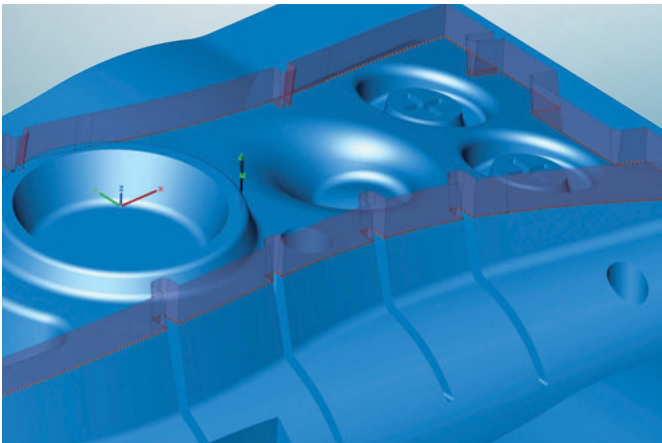

## Linear sweep

Extension for the linear sweep face with angle from 3D contours. Transitional areas are filled automatically.

**Benefit:** Simple to create face extensions.

## Image CAD element

*hyperCAD®-S* offers the option of inserting image files into the CAD system. This can be used for title blocks and to trace milling areas, for example.

**Benefit:** User-friendly.

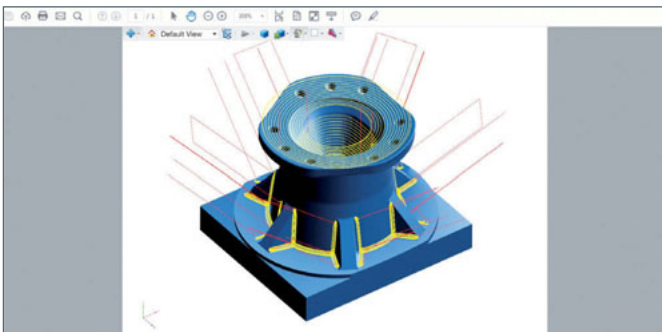

## Export 3D PDF

This is a new export option for creating 3D PDF files. 3D models can be shown with text, dimensions and toolpaths.

**Benefit:** Displayed in a neutral data format.

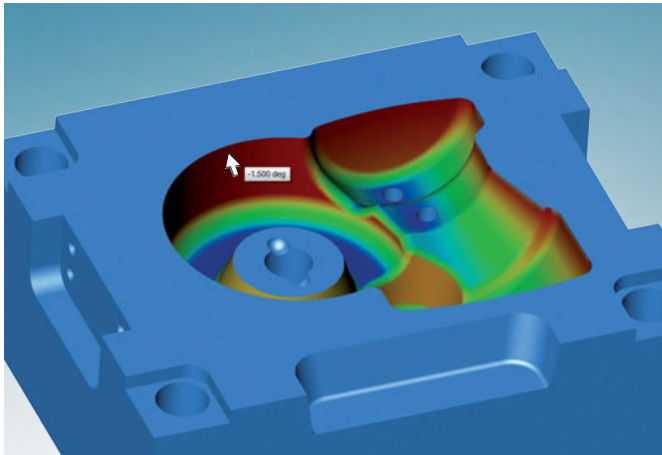
**Highlight****Draft analysis**

New functions are available for draft analysis. Information on angles can be displayed as a tooltip. By setting a boundary for the draft angle, a curve can be extracted for limiting the milling area.

**Benefit:** Fast analysis of milling areas and support for creating milling areas.

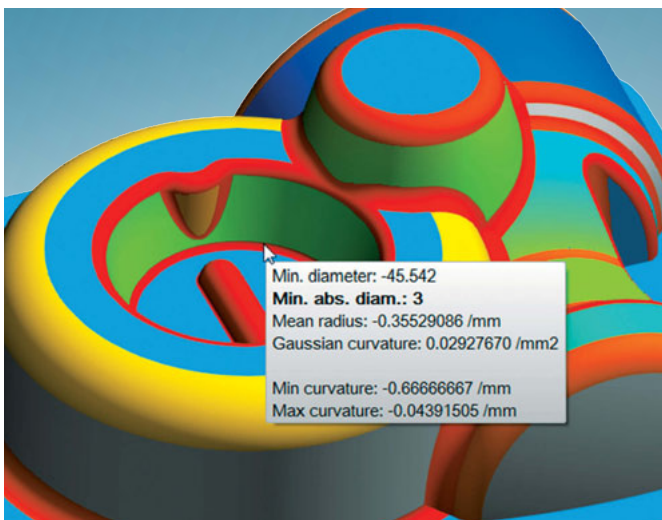
**Highlight****Curvature analysis**

Curvature analysis is a new function that includes four options.

- Mean curvature
- Gaussian curvature
- Minimum radius of curvature
- Absolute minimum radius of curvature

In addition, the curvature information is displayed as a tooltip and a curve can be extracted from a delimited area.

**Benefit:** Fast analysis of radii sizes.

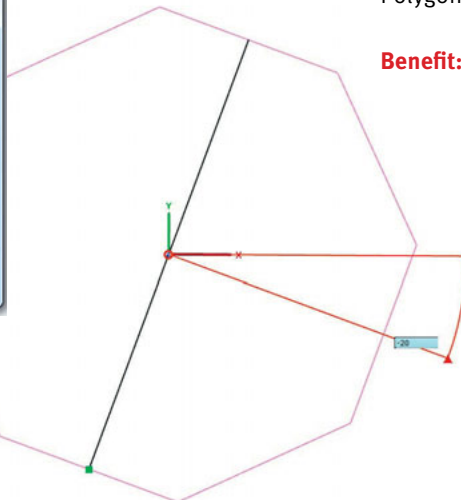
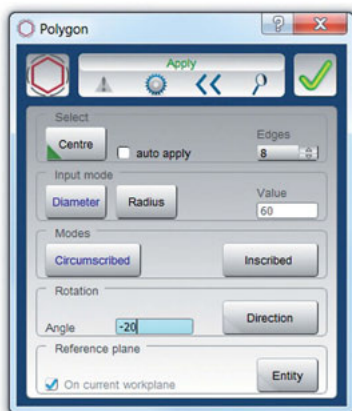
**Polygons**

Polygons can be created quickly via a simple definition.

**Benefit:** User-friendly.

**Headquarters**

**OPEN MIND Technologies AG**  
Argelsrieder Feld 5 • 82234 Wessling • Germany  
Phone: +49 8153 933-500  
E-mail: Info.Europe@openmind-tech.com  
Support.Europe@openmind-tech.com

**UK**

**OPEN MIND Technologies UK Ltd.**  
Units 1 and 2 • Bicester Business Park  
Telford Road • Bicester • Oxfordshire OX26 4LN • UK  
Phone: +44 1869 290003  
E-mail: Info.UK@openmind-tech.com

**USA**

**OPEN MIND Technologies USA, Inc.**  
1492 Highland Avenue, Unit 3 • Needham MA 02492 • USA  
Phone: +1 888 516-1232  
E-mail: Info.Americas@openmind-tech.com

**Brazil**

**OPEN MIND Tecnologia Brasil LTDA**  
Av. Andromeda, 885 SL2021  
06473-000 • Alphaville Empresarial  
Barueri • Sao Paulo • Brasil  
Phone: +55 11 2424 8580  
E-mail: Info.Brazil@openmind-tech.com

**Asia Pacific**

**OPEN MIND Technologies Asia Pacific Pte. Ltd.**  
33 Ubi Avenue 3 #06-32 • Vertex (Tower B)  
Singapore 408868 • Singapore  
Phone: +65 6742 95-56  
E-mail: Info.Asia@openmind-tech.com

**China**

**OPEN MIND Technologies China Co. Ltd.**  
Suite 1608 • Zhong Rong International Plaza  
No. 1088 South Pudong Road  
Shanghai 200120 • China  
Phone: +86 21 588765-72  
E-mail: Info.China@openmind-tech.com

**India**

**OPEN MIND CAD/CAM Technologies India Pvt. Ltd.**  
3C-201, 2<sup>nd</sup> Floor • 2<sup>nd</sup> Main Road • Kasturi Nagar  
Bangalore 560 043 • Karnataka • India  
Phone: +91 80 3232 4647  
E-mail: Info.India@openmind-tech.com

**Japan**

**OPEN MIND Technologies Japan K.K.**  
Misumi Bldg. 3F • 1-17-18, Kichijojihigashicho  
Musashino-shi • Tokyo 180-0002 • Japan  
Phone: +81 422 23-5305  
E-mail: info.jp@openmind-tech.co.jp

**Taiwan**

**OPEN MIND Technologies Taiwan Inc.**  
3F., No.153, Huanbei Rd., Zhongli Dist. • Taoyuan City 32055  
Taiwan (R.O.C.)  
Phone: +886 3 46131-25  
E-mail: Info.Taiwan@openmind-tech.com

OPEN MIND Technologies AG is represented worldwide with own subsidiaries and through competent partners and is a member of the Mensch und Maschine technology group, [www.mum.de](http://www.mum.de)

[www.openmind-tech.com](http://www.openmind-tech.com)



We push machining to the limit